

BIOSOLUTIONS

**PUMPS, CONTROLS & REGULATIONS
FOR MORE INFORMATION
CALL (818) 991-9997**

<http://www.biosolutions.org>

This paper was first presented by Terry R. Bounds, P.E., at the 1995 Northwest Onsite Wastewater Treatment Short Course and Equipment Exhibition. This article may describe design criteria that was in effect at the time the article was written. FOR CURRENT DESIGN CRITERIA, call Orenco Systems, Inc. at 1-800-348-9843.

Pumps, Controls and Regulations

Terry R. Bounds, P.E.*

Abstract

In many areas today's onsite alternatives are required to provide higher levels of treatment than a standard septic tank drainfield system. These alternatives are more complex and typically rely on uniform distribution and periodic dosing of pretreated effluent from well designed septic tanks. Dosing and pressure distribution are standard practices for subsurface disposal and many other secondary treatment processes. The primary method for dosing and distributing effluent is with a pump. Installation of pumps, electrical controls, alarms and sensors by a qualified electrician is required by local, state, or national codes. Regulatory and/or governing agencies, and national associations like The National Fire Prevention Association are addressing onsite electrical issues more specifically in their recommended practices and codes. Improving quality and continuity throughout the industry in order to improve system performance and reliability is a major focus.

Key words

Controls, pumps, power, sensors, regulations, dosing

Onsite Applications

Research and development since the early 1970s has taken great strides in bringing to the public affordable, efficient, and reliable methods of collecting and treating wastewater. Effluent sewer development for community collection systems began about 1970, although the concept was conceived many years earlier. Advancements in onsite treatment methods were also beginning to take hold about that time. By the late 1970s it was apparent that these alternatives would change the way we chose to convey and treat domestic wastewater. However, the availability of reliable equipment necessary to make these technologies successful was virtually non-existent.

Early designs would generally specify functions and performance, and rely on specialty shops to customize the assemblies based on local regulations and minimal design information and/or requirements. This typically resulted in confusing comparisons between specialty supplies. Consequently, *performance-based specifications* are being blended together with *prescriptive component selections* to ensure designers, regulators and users greater reliance and uniformity.

As rural development continues to progress, the availability of suitable land for standard gravity application declines. This leads to stricter treatment requirements and regulations, which stimulates the need for more efficient technologies. These alternatives are more complex, and typically rely on uniform distribution and periodic dosing of pretreated effluent from well designed septic tanks.

Dosing and pressurized distribution are practices commonly used in most secondary treatment processes and are becoming equally common in onsite treatment technologies. As the hydraulic loading rate (HLR) increases, removal of bacteria and viruses decreases (EPA, 1977; Dymond, 1981). Increasing the dosing frequency (*number of occurrences over a given time period*) reduces

*T. R. Bounds, P.E., Vice President, Orenco Systems, Inc., Sutherlin, Oregon.

the volume of wastewater applied per dose and increases coliform removal (Mohammed, 1991). The value in dosing comes from its *intermittent* nature. Eliassen (Sproul, 1975) observed that increased loading rates resulted in decreased removal of viruses in soil mediums. Therefore, by keeping the dosing periods *short* the instantaneous *hydraulic* and *organic* loads are reduced. Short doses followed by extended resting periods spread throughout the day increases the liquid to media contact time, which enhances microbial activity and improves treatment. The value of pressurized distribution is also in its ability to improve treatment and site longevity by spreading the load in smaller, discrete volumes, more uniformly over the treatment area.

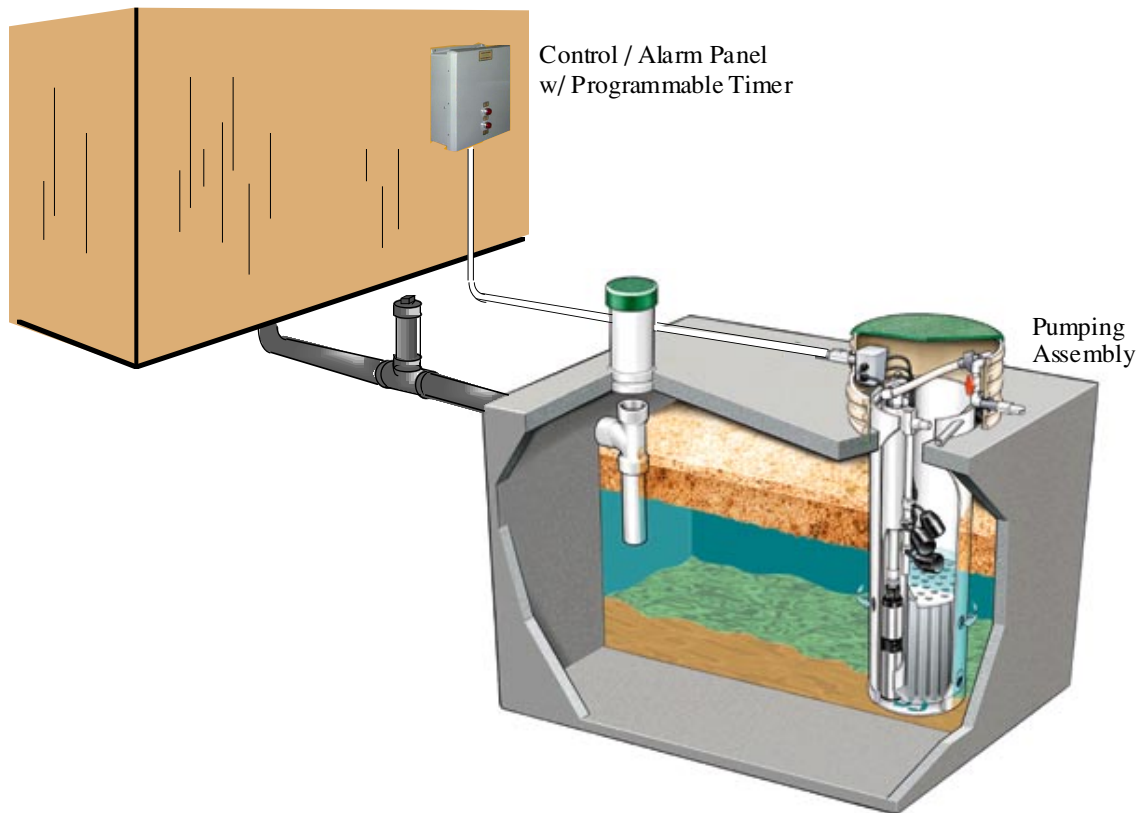

Figure 1: Septic Tank and Pumping Assembly

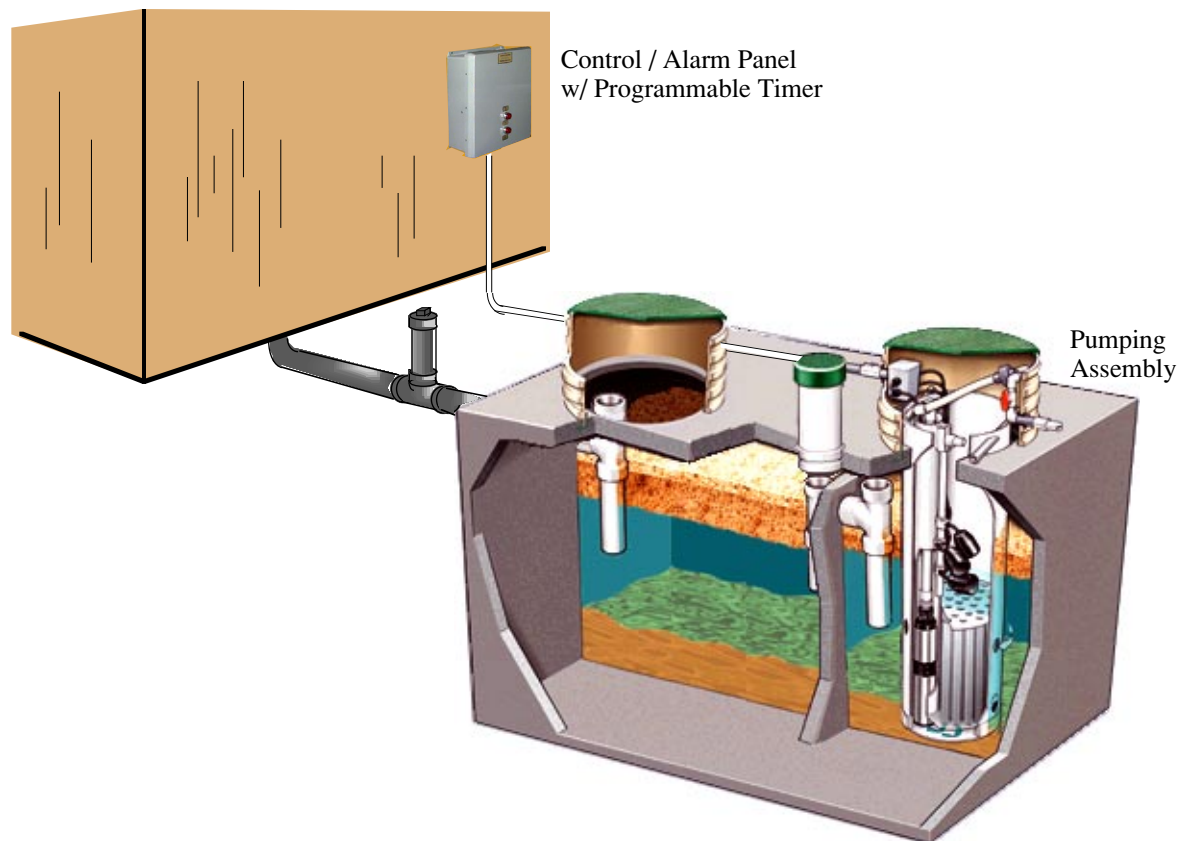

Figure 2: Dual Compartment Septic Tank with Pumping Assembly

The EPA (1978 report) concluded from the Wisconsin work (Green and Cliver, 1974) that, *the key to successful sand filtration of septic tank effluent, in terms of virus retention, is to divide the fluid load into enough small portions as to permit increased retention time in the filter to allow adhesion of virus to physical and biological surfaces within the filter.* The primary method for dosing and distributing effluent is with a pump. Control systems with liquid level sensors and programmable timers offer the most efficient method of dosing. Programmed dosing also provides a way to ensure unsaturated flows through the medium. Powelson and Gerba (1994) found that *virus removal was much greater under unsaturated flow conditions.* At the University of California, Davis, Mohammed (1991) observed that more frequent dosing (*timer controlled*) resulted in better performance and more *consistent* results. Timer-controlled dosing may be accomplished from multiple or single compartment tanks. Two typical tank configurations are shown in Figures 1 and 2.

System Controls

The controls and sensors ensure the system will operate efficiently and sound an alarm when malfunctions threaten efficient performance. The *primary functions* include, but are not limited to, high-water alarm, high-water overrides, “on” and “off”. Commonplace *secondary functions* include low-water alarms and redundant off, intrinsically safe control relays for classified pumping locations, automatic shutoffs to prevent dosing pumps from flooding sand filters, or programmable timers for dose control operations. Telemetry, current sensing, programmable controllers, time delays and other *special options* are also available. The *special options* are considered too costly for most residential applications.

Standard control/alarm panel features should include circuit protection and disconnects, manual, off and automatic motor control operation, an audio/visual high-water alarm circuit with audio silence, and automatic reset upon correction of the high-water condition.

Septic tanks and alternative onsite wastewater systems are no longer considered to be temporary collection and treatment solutions. The controls, therefore, need to be of sufficient quality that will ensure the long-term reliability expected of permanent systems. Components must also be investigated carefully to ensure consistency and dependability with respect to each other and the pumps they control. Selecting, for instance, a relay or motor contactor based on simple power or amperage ratings may provide only short-term reliability. An example is the electronic tinkerer who rigs up a working control system with a wristwatch, or off the shelf integrated circuit chips (IC's) and sprinkler system parts. The long-term reliability is most likely sacrificed, and the serviceability of the system will rely on its creator's memory. This type of system outfitting is dreaded by new owners, regulators and repair personnel. Uniformity throughout the industry is paramount, especially as it relates to reliability and serviceability. To ensure this, control and alarm panels need to be listed by an accredited agency (e.g., UL or CSA); their components need to be listed or recognized by the same accrediting agency.

Devices such as elapsed time meters and counters are also common and recommended for system monitoring. Control systems are now available that will sound alarms when the water level is too low (leaking tank) or when too much water is passing through the system (stuck toilet valve). They can also dose at predetermined times, regardless of varying inflows, in order to reduce the collection system's hydraulic gradient or peak hydraulic overloads. A basic simplex control panel is shown in Figure 3.

The basic components and features of this control panel include the following:

- A. **Programmable Timer:** Precisely controls the pumping doses. The timer is programmed so that the "on" time (*dosing period*) is short; therefore, effluent is dosed in small volumes. This enhances the effluent to media contact time by preventing hydraulic channeling through the secondary treatment media; better oxygen transfer and biological reduction result. The "off" setting modulates doses uniformly throughout the day, thus impeding short-term hydraulic overloads due to peak flow or faulty fixtures. Uniformly spaced resting periods between doses improves performance and aerobic degradation of the biomass. Programmable timers are also beneficial in systems that need surge control, where a long period of storage is required between intermittent or batch feed discharges (e.g., churches, schools, batch plant process, etc.) Timers are available with digital or analog features, and should be capable of a repeatable cycle from 10 seconds to 10 hours with separate variable controls for the "on" and "off" times. The timer is typically energized and de-energized by the "on"/"off" float; therefore, the low liquid level is controlled by the float's "off" level. Another feature the system provides is an awareness for periods of excessive water usage or abuse.

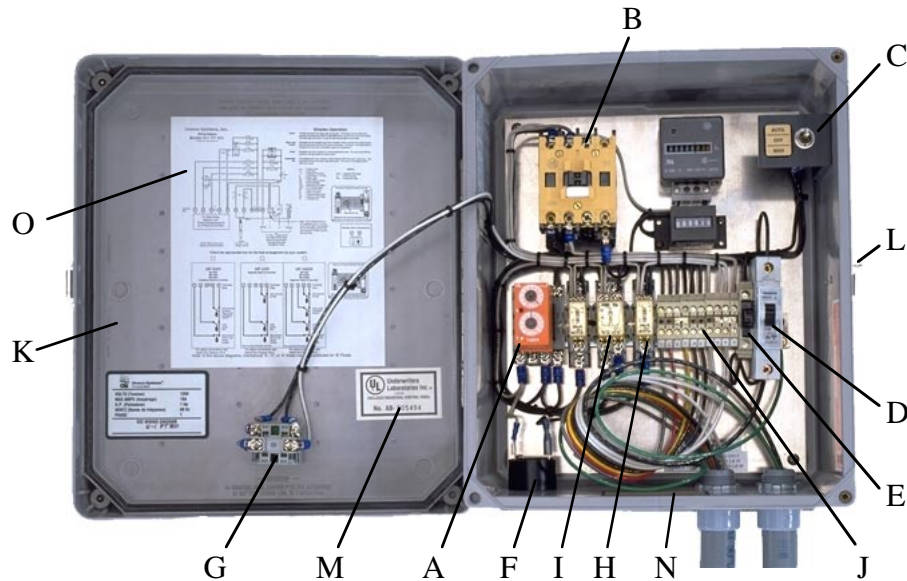

Figure 3: Simplex Control Panel with Programmable Timer

- B. **Motor-Start Contactor:** Switches power to the pump on command from the programmable timer’s signal. Motor contactors may be rated for the pump load, although their life rating must accommodate years of uninterrupted service (i.e., evaluate the contactor’s rated number of mechanical operations and the full load amperage life of the contacts).
- C. **Toggle Switch:** Allows the pumping operation to be automatically or manually controlled, or switched off without interrupting the programmable timer’s memory.
- D. **Current Limiting Circuit Breaker:** Provides a disconnect means and secondary overload protection for the pump circuit. Service entrance rated circuit breakers must be used when the input power is supplied directly from a meter base and not from a main breaker panel.
- E. **Fuse Disconnect:** Provides a separate disconnect means and overload protection for the control circuitry (e.g., alarm system, motor contractor, programmable timers, relays, etc.) Power to the alarm and control circuitry is wired separately from the pump circuit, thus, if the pump’s internal overload switch or current-limiting circuit breaker is tripped, the alarm system remains functional.
- F. **Audible Alarm:** Provides an audible alarm when a high or low liquid level requires correction. The alarm should be loud enough to provide ample warning but not so loud that it causes irritation. A minimum of 80 db sound pressure at 24 inches is recommended, and a “warble” is preferable over a continuous tone. A push-to-silence feature should also be included so that the alarm noise does not become a nuisance.
- G. **Visual Alarm:** Provides visual indication when there is a high or low water level that requires attention. The alarm light is usually red and available in many sizes and shapes. The light assembly’s environmental rating (i.e., corrosion resistant, rain or spray resistant, etc.) must be consistent with required panel rating.
- H. **Audio-Alarm Silence Relay:** Automatically resets the audio alarm after the alarm condition has been corrected.
- I. **Redundant-Off/Low Level Alarm Relay:** Automatically overrides the pump control circuit to shut down the pump and energize the alarm system to signal a low level condition.

- J. **Terminal Blocks:** Touchsafe type terminal blocks provide greater protection against accidental shorting across terminals and touching of live connections. Terminal space should be available in the motor control panel for connection of remote alarm equipment.
- K. **Enclosure:** Should be constructed of materials that are noncorroding and durable, and NEMA 4 or 4X-rated to ensure adequate environmental protection for the enclosed components.
- L. **Padlockable Latch:** Provides lock-out capability to ensure security and protection for maintenance and monitoring.
- M. **Listing:** All controls should be manufactured by a company listed by an approved accrediting agency (e.g., UL, CSA or ETL). Check with local regulators for a list of approved listing agencies and the appropriate standards.
- N. **Warnings and Instructional Stickers:** All control systems must contain the proper electrical warnings and instructional information to ensure user awareness and safety.
- O. **Wiring Diagram:** Provides float and pump wiring instructions and information regarding the intended function of each component. A wiring schematic must be provided and kept in all panels for future reference of the features and functions of the controls.

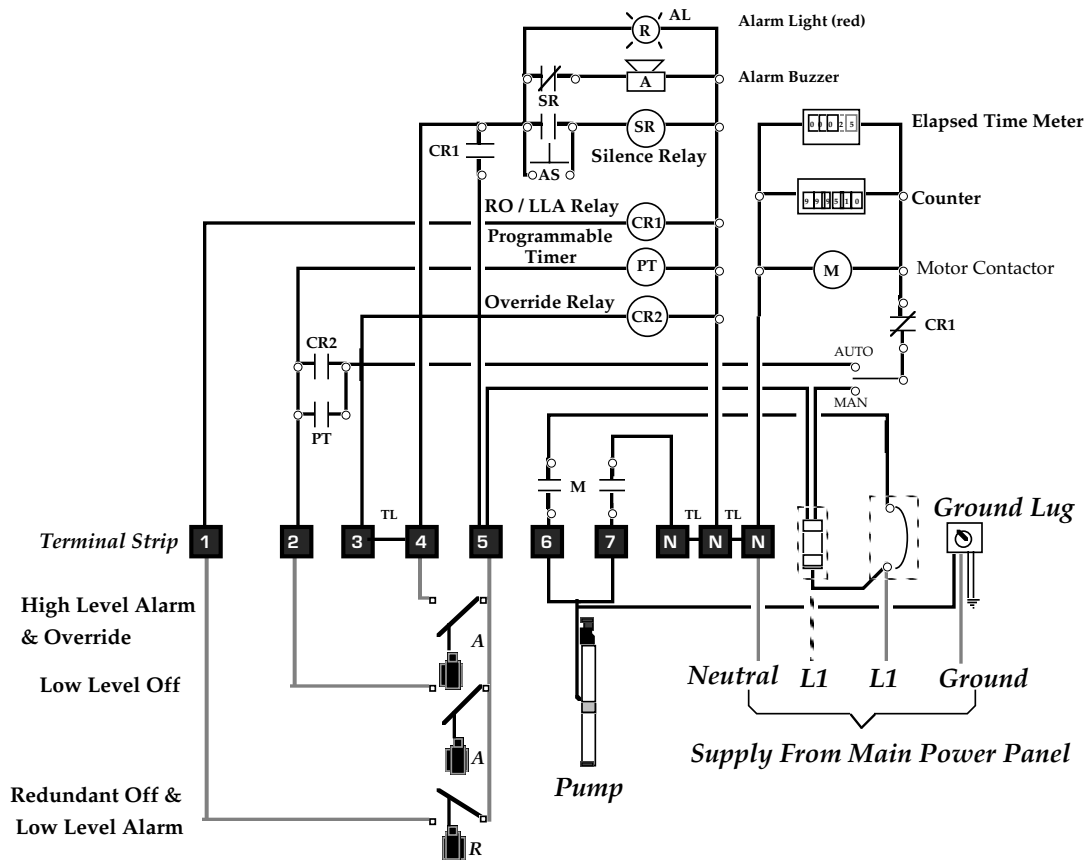

Figure 4: Control Panel Wiring Schematic

Figure 4 illustrates a wiring schematic for a simplex control/alarm panel with programmable timer, redundant off and low-water alarm, override relay, elapsed time meter and event counter options.

Control/alarm panels are usually located on the side of the house at a height that is convenient and accessible for maintenance. They should be close to and in sight of the pump and out of the direct sun and rain. Very hot or cold temperatures can cause variations in the performance of the electrical components.

A high or low liquid level may activate the audio/visual alarm system. The audio circuit may be silenced, but the visual indicator must display until the liquid level condition is corrected. Once the alarm condition has been corrected, the circuitry should automatically reset. When an alarm occurs, the user should call either the district's phone number (usually located on the panel cover), or if they are not in a district, an accredited maintenance service. An average 24 hour reserve storage is provided above the alarm level, so onsite problems do not normally require immediate attention. Therefore, typical alarm problems can be responded to during convenient work hours, usually within 24 hours of the call.

When servicing any control system, all warnings must be given strict attention. An operator must not work on any system without first disconnecting the power at the circuit breaker and/or disconnect fuse. All control panels should be provided with a lockable latch to ensure the operator's safety while working in the splice box away from the control panel.

Level Control Sensors

Control panels are typically designed for use with mercury or mechanical float switches, and are normally compatible with any standard dry-contact switching method. Used correctly, mercury and mechanical switch floats have proved to be reliable and accurate. Dozens of types are available, so it is important that the system designer specify exact model numbers. Floats should always be securely attached to a support stem designed for that purpose. Strapping floats to the pump discharge pipe is not good practice since pump vibration tends to loosen the straps, causing the floats to slip from their settings. Moreover, removal of the pump for any reason requires that strapped-on floats be readjusted. Liquid-level float settings are based on a minimum separation between the "alarm" and the "on" level and the drawdown between "on" and "off" or "redundant off".

The high water alarm and "on-off" floats are normally open switches, which close (turning on the function) when the float tips slightly above the horizontal position. The "redundant off - low level alarm" float is a normally closed switch; therefore, the circuit is open and in the off position as long as the float stays buoyed above its horizontal position. Figure 5 illustrates a few ways to accomplish these level control functions with floats.

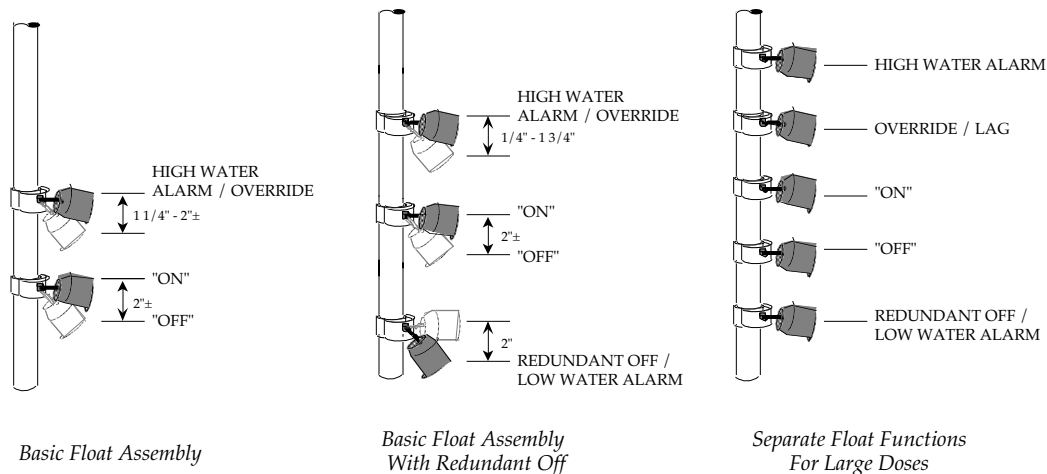

Figure 5: Level Control Float Assemblies

Floats must be omni-directional (not sensitive to rotation), impact resistant, non-corrosive, watertight and listed for water and sewage with an accredited agency (e.g., UL or CSA). Pilot duty switches can carry a small current (usually 5 amps or less) and are used primarily to signal liquid level conditions to other components in the control panel. Motor-rated switches are capable of switching full motor currents as well as signaling timers, relays and other control components. When a motor-rated switch is used to eliminate the motor contactor, the full current switching takes place in the pumping vault, and where troubleshooting is awkward and more laborious. Motor contactors offer greater equipment life, reliability, safe and easier maintenance, and much greater monitoring and operating options.

On-off floats are available with effective drawdowns of about 2 inches. The small operating zone created by this short drawdown maximizes scum and sludge storage volumes in dosing septic tanks, thus more efficiently utilizing the tank's biological capacity.

Positioning the floats begins by establishing the "off" level. The "off" level depends on the occupancy flow rate, the reserve and hydraulic retention times, the method of dosing and the accumulation of scum and sludge within the tank.

The following example demonstrates how to set the float levels and programmable timer cycle for a 1500 gallon single-compartment tank (serving an occupancy of four), and a standard 18 foot x 20 foot intermittent sand filter with sixty-four 1/8-inch diameter orifices:

- Wastewater flows for single-family dwellings typically range from 40 to 60 gallons per capita per day (gpcd); 50 gpcd is a commonly-used design parameter and is the value used in calculations herein. The number of individuals (capita) is assumed to average four (4); therefore, the average flow is 200 gpd.
- The reserve space is that portion of the tank from the soffit to the top of the scum layer when the liquid level is at the alarm stage. The reserve volume typically allowed is usually sufficient to permit 24 to 48 hours of normal use, in case of malfunction, before repairs must be made. For four occupants allow a minimum of 200 gallons for reserve volume.

- The *clear zone* lies between the scum and sludge layers. When a tank’s hydraulic retention time is sufficient for settlement, the clear zone contains liquid waste fairly free of solids. Dunbar¹, Laak² and Winneberger³ suggest minimum retention times from 6 to 24 hours for adequate suspended solids removal. Minimum sludge and scum *clear spaces* must also be maintained to ensure the effectiveness of the clear zone. The *scum clear space* is the distance between the bottom of the scum layer at the pump’s “off” level and the outlet (top of the discharge ports) of the septic tank. The recommended minimum allowable is 3 inches. The *sludge clear space* is the distance between the top surface of the sludge and the outlet (bottom of the discharge ports) of the septic tank. For tanks having a surface area of 27 square feet or more, the recommended minimum is 6 inches. The minimum clear zone depth is about 10.5 inches (325 gallons in a 1500 gallon tank), which provides for more than 24 hours of hydraulic retention time for a 200 gpd system. Once any of these minimum conditions has been reached the tank must have its solids pumped out.
- The *operating zone* is that portion of the tank between the “off” level and the “high-water alarm” level. Keeping this zone small has the advantage of maximizing volumes of sludge and scum that can be stored and minimizing disturbance of the scum layer during pumping cycles. The operating zone for systems that use programmable timers should allow for 24 hours of storage between the timer “on” level and the “high-water alarm” level, plus the float’s 2-inch drawdown. Therefore, the total operating volume is 265 gallons (200 gallons for the average daily flow, plus 65 gallons for the timer control float’s 2-inch drawdown). The total operating depth is about 8 inches from the “off” level to the “high water alarm level”.
- Based on standard residential accumulation rates for sludge and scum, the optimum effluent withdrawal elevation from the floor of the tank to the center of each inlet port calculates to be about 28 inches as shown in Figure 6.

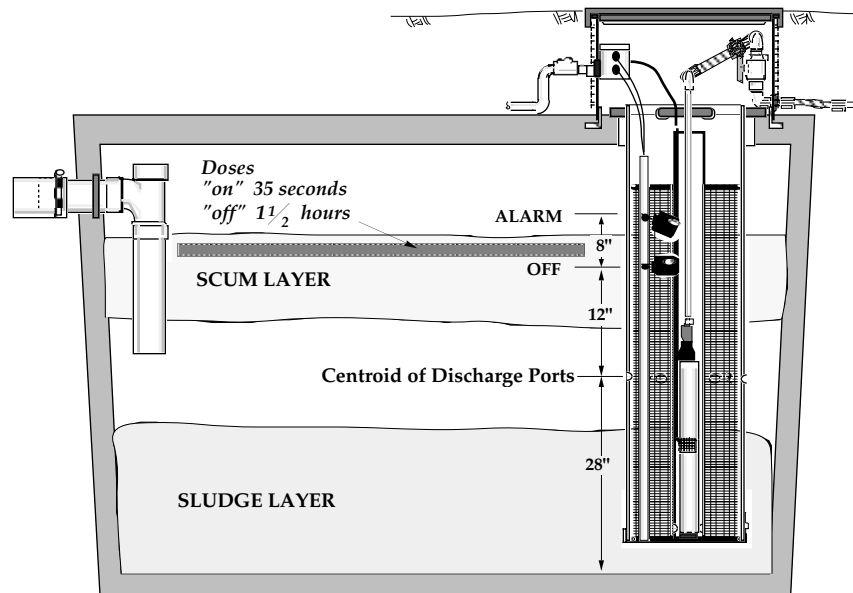

Figure 6: Float Levels in a 1500 Gallon Tank Serving Four Occupants.

- The minimum operating liquid depth (“off” level) is 40 inches from the floor of the tank—twelve inches above the center of the outlet ports. Thus the discharge ports are centered at 70% of the

lowest operating liquid level, which is consistent with the regulation adopted by many governing jurisdictions requiring the withdrawal elevation to be at 65 to 75% of the lowest operating liquid depth.

- Laterals with $\frac{1}{8}$ -inch diameter orifices are designed to operate at a 5 foot pressure residual at the most remote orifice. *Therefore, the pump's dosing rate will be about 28 gpm* ($\approx 64 \times 0.433$).
- To enhance the quality of treatment of the effluent as it passes through the media the dose is limited to about $\frac{1}{4}$ of a gallon per orifice per cycle. *Therefore, the dose volume will be about 16 gallons* ($\approx \frac{64}{4}$); *the subsequent "on" time will be set at about 35 seconds* ($\approx \frac{16 \times 60}{28}$).
- The "off" time, for residential applications, is based on the number of doses that occur in an 18-hour operating day. The number of doses will be about 13 per day ($\approx \frac{200}{16}$). *Therefore, the "off" time will be set at about 1 $\frac{1}{2}$ hours* ($\approx \frac{18}{13} - \frac{35}{3600}$).

The operating volume is sufficient to allow periodic surges from normal and peak daily wash cycles, showers, etc. During normal operation, the system will reach the timer "off" float level each night. When the timer "on" level is reached, about 65 gallons of the daily flow has come into the tank. The remaining 135 gallons of the daily flow is expected to be discharged to the tank throughout the normal active hours of the day (typically 5:30 AM to 11:30 PM). The top 4 inches of the operating zone will not be used during normal operating conditions; this surge space should accommodate peak wash days with little concern for triggering the high water alarm.

Flow that occurs during peak days may trip the high water alarm, but should not be excessive as to cause a nuisance (i.e., infrequently and corrects itself quickly). The timer controlled method of dosing warns users of excess water usage, often caused by a stuck toilet valve, building sewer I & I (infiltration/inflow), leaky tanks or faucets; the typical float controlled pumping method passes the excess flow without warning. Besides enhancing the quality of treatment, timer controlled dosing also tends to bring the user to a higher level of awareness. Peak day or excessive flows that trip the high water alarm float will energize the pump, which will discharge until the alarm float's "off" level is reached (*pumping out about 65 gallons from a 1500 gallon tank*). Sand filters have sufficient capacity to handle periodic large flow days with little degradation of effluent quality.

Splice Box

Typically a splice box for the float and pump cords is installed in the riser near ground level for easy access (refer to Figure 6). The splice box is required so that electrical components (pumps and float switches) can be safely and legally removed and replaced. The splice box is used to house spliced wire connections in the riser between an electrical control panel and equipment such as effluent pumps and float switches. The splice box, cord grips and appurtenances must be non-corrosive and rated as water resistant with an accredited agency (e.g. UL or CSA). The floats are installed as an assembly and the float and pump cords are threaded through the splice box's cord grips where the individual wires are connected to wires from the control panel, as shown in Figure 7.

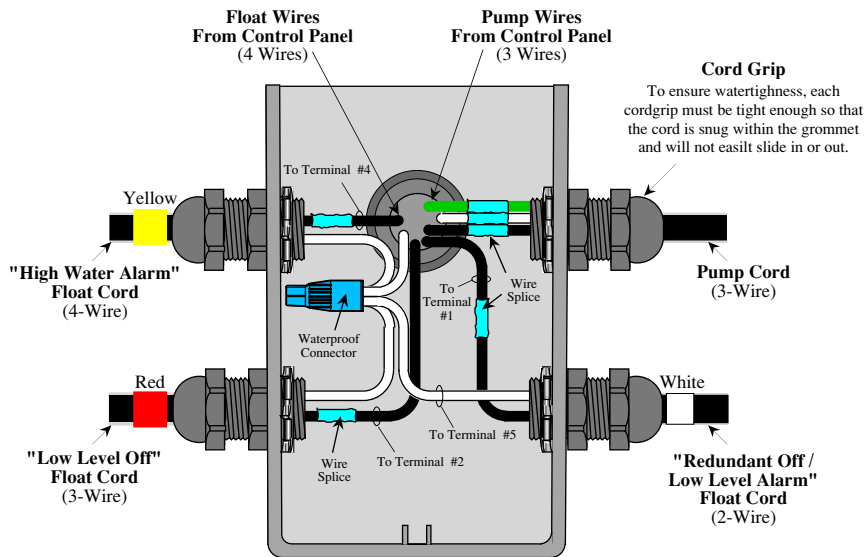

Figure 7: Electrical Splice Box Assembly

The cord grips should be tightened by hand, not by tool. Check the tightness by tugging on the cords; the cord is secure and considered watertight when the cord grip is tight enough to prevent slippage. An adequate length of cord should be left within the splice box to allow for easy removal for future disconnecting and re-splicing.

All splices made in the splice box should be done using waterproof wire nuts or butt connectors and heat shrink tubing. The splices **must** be waterproof! Splices that are not watertight may cause a nuisance alarm or malfunction if too much water leaks into the splice box. If moisture builds up on the conductors in the junction box, voltage may bleed back through non-watertight wire nut connections to the audible alarm, causing a low decibel buzzing. Water vapor trapped in a sealed junction box when condensed should amount to no more than a few drops. Accumulation of more than a few drops of water indicates the box is not sealed. The cause may be loose cord grips, an unsealed lid, or an inadequate conduit seal. Muddy water inside the junction box could be the result of infiltration through the conduit fitting. Waterproofing the connection at the threaded nipple outside the riser, between the conduit seal and the junction box adapter, solves many conduit infiltration problems.

The wires between the splice box and the control panel may be placed in conduit or direct buried using a suitable direct-burial wire and burial depths. The number and size of wires should be as specified by the manufacturers or the National Electric Code (NEC). Wire that is too small will cause excessive voltage drop and degrade pump performance. To ensure adequate starting torque and running performance, the lengths are calculated per the National Electric Code to maintain 95% of the service entrance voltage at the motor when running at full load amperage (FLA). The full load current in amperes is the current when the motor is running at usual speeds near the full-load working or shut-off side of the performance curve. A motor's nameplate current rating takes precedence when it exceeds the NEC's minimum. It is common for pump manufacturers to provide some guidance for proper wire selection and circuit protection based on the energy demands of their products. Wiring should be color coded, or otherwise

marked to aid in wiring the control panel. The colors could be either the color of the wire's insulation, or the color of a tag or electrical tape. Table 1 lists some common colors used in field wiring.

<i>Floats</i>	<i>Float Tag</i>	<i>Wire Color</i>
High Water Alarm	Yellow	Yellow
Lag #3 Pump On (Quad)	(Purple)x3	Tan
Lag #2 Pump On (Tri & Quad)	(Purple)x2	Pink
Lag Pump On (Duplex)	Purple	Purple
On / Lead Pump On	Blue	Blue
Off / Pumps Off	Red	Red
Low Level Alarm	Orange	Orange
Redundant Off	Grey	Grey
Redundant Off & Low Water Alarm	White	Grey
Float Common Wire		Brown
<i>Pumps</i>		
Pump Wire (L1)		Black
Pump Wire (L2 or Neutral)		White
Ground		Green

Table 1: Typical Field Wire Colors

The final step before testing is to wire the float and pump cables to their appropriate terminal connection in the control panel. The wires must be connected in strict accordance with the specific float arrangement and control panel wiring diagram. Color-coding should help ensure correct termination the first try.

Pumps

Effluent pumps are available in many models and styles, from single-stage centrifugal pumps to multi-stage turbine pumps. The ideal discharge rate for an effluent sewer pump, serving a single-family residence, is 5 gpm. Where system pressures are low it's common to use flow controllers to keep the discharge rate below 9 or 10 gpm. Intermittent filters and pressure distribution system will require larger flows, however, from a single compartment tank the maximum discharge recommended is 30 gpm. For flow rates greater than 30 gpm, multiple compartment or separate dosing tanks are used.

Pump selection is made after the energy gradient or system curve for the collection or distribution system has been established. The selection is made by determining the total dynamic pumping head (TDH) in feet of pressure. The friction losses in the discharge assembly (h_{hv}), transport line (h_f) and manifold (h_m) are computed based on the pump discharge rate and lateral flows, and then added to the residual head (h_r) and the static head (h_s). See Figure 8.

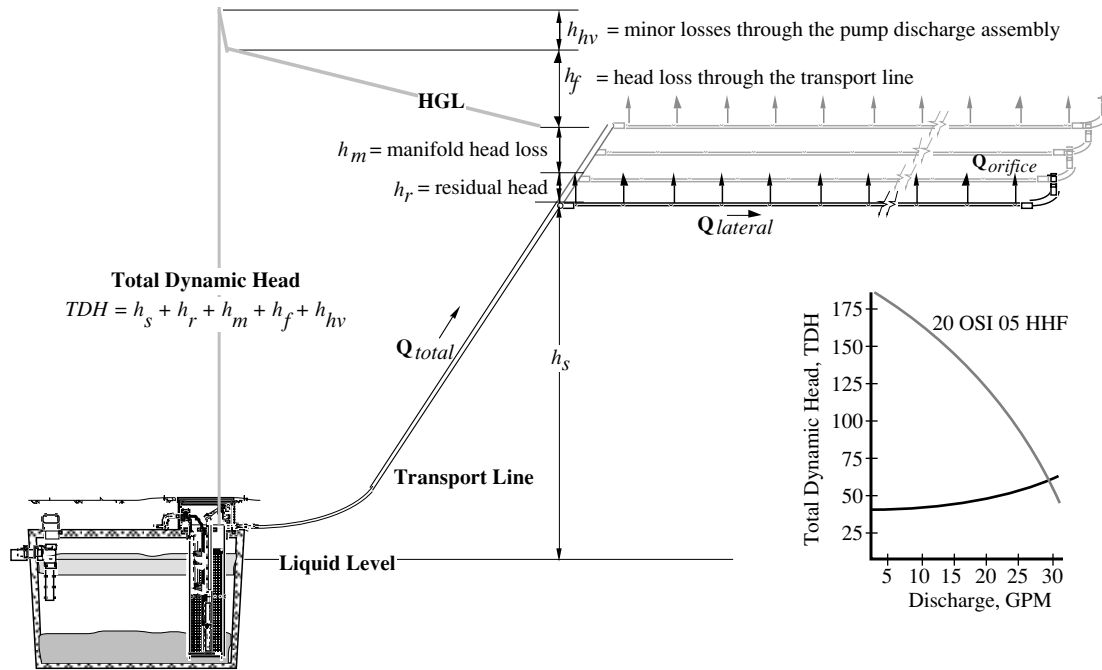

Figure 8: Pressure Distribution System and Energy Gradient

In our previous example we have sixty-four $1/8$ -inch orifices with a flow demand of 28 gpm. The hydraulic gradient is established by the elevation of the residual pressure required at the terminal ends of the distribution laterals. Given that $1/8$ -inch orifices are used with a five foot residual, it can be determined from an evaluation of each pumps' characteristic discharge curve the maximum static and dynamic heads they can satisfy. For instance, at 28 gpm the one-half hp, 20 gpm turbine pump can accommodate about 55 feet of static and dynamic head whereas a 1 $1/2$ hp effluent pump would be required to do the same work. See Figure 9.

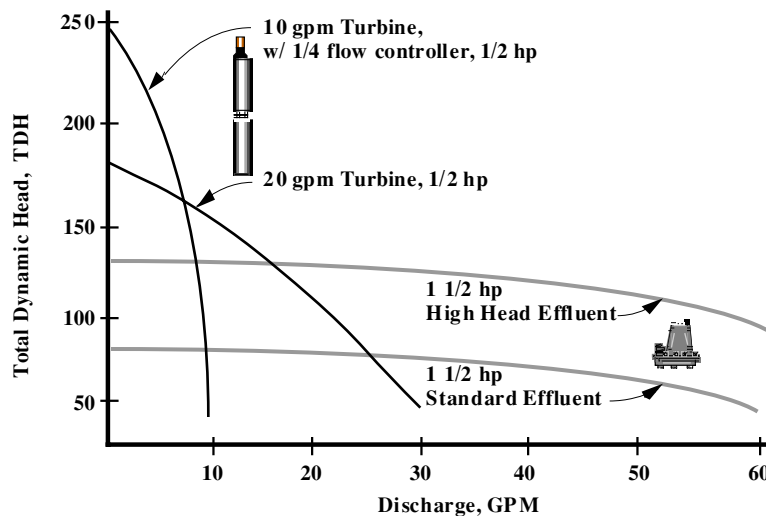

Figure 9: Effluent Pump Options

Submersible turbine pumps are common in effluent sewer systems because of their extreme resistance to corrosion, high cycle life (250,000), light weight (25 lbs.), ability to pump 5 to 20 gpm at discharge heads greater than 200 feet with fractional horse powers, and overcome air binding problems. In pressure distribution systems they will provide more than sufficient energy to flush laterals and help keep orifices clear. Another advantage is their ability to operate for extended periods in the “no discharge” condition, or at heads greater than the maximum “shut-off” head. The following list covers some advantages offered by submersible turbines:

1. **Abrasion and Corrosion Resistance.** Constructed entirely of 300 Series stainless steel and thermoplastics, submersible well pumps are designed and built to withstand fluids harsher than septic tank effluent. The cast iron of standard effluent pumps require baked-on epoxy paints which may provide only short-term protection.
2. **Single Selection.** Traditional effluent pumps selected to satisfy pumping heads from 25' to 150' TDH, would run the gamut from $1/2$ Hp to $1 1/2$ Hp, while a single model ($1/2$ Hp, 10 GPM) submersible turbine pump could be used throughout that entire TDH range. A “one pump” solution simplifies design, inventory, and maintenance.
3. **Lower Initial Cost.** A $1/2$ Hp submersible pump costs about 40 percent less than an equivalent duty single-stage effluent pump.
4. **Submerged Motor.** The motor of a submersible well pump is positioned *below* the fluid intake. The motor remains submerged even in the event the level control system fails to turn the pump off. A submerged motor not only reduces the potential for corrosion, but is, in fact, required where the environment has been declared hazardous (Class I, Division 1).
5. **Low Flow Rate.** The ideal flow for a single-family unit is about 5 GPM, a rate easily accomplished with submersible well pumps and flow controllers. At this flow rate, the contents of the septic tank are barely disturbed and the solids carryover is minimized. This low flow rate makes it possible to use smaller collection pipes throughout the system. Standard effluent pumps, on the other hand, deliver much higher flows. In fact, during the initial years of a newly constructed pressure sewer, before the system’s hydraulic gradient becomes fully developed, all the effluent pumps will typically pump at a very high flow rate, often 60 GPM or more. Discharge from single compartment tanks should remain less than 30 gpm so the effluent quality is not degraded.
6. **Ease of Maintenance.** A $1/2$ Hp submersible well pump weighs only twenty-five pounds and may be removed without the assistance of an awkward lifting mechanism. At about 50 pounds, lifting mechanisms are usually required to eliminate potential back strains, which is a key reason why maintenance personnel favor turbine pumps.
7. **Low Operation Cost.** Smaller, more efficient motors consume less energy and require fewer wiring changes in most residential units.

Pump Comparison

Submersible Effluent Pumps:

- Pump sizes ranges from $1/4$ to $1 1/2$ Hp; 115 VAC when $1/2$ Hp or less, 230 VAC when $3/4$ Hp or greater; 2 Hp models are also available, however they generally require special control considerations to ensure that adequate starting torque is provided.
- Solids handling capacity ranges from $1/4$ inch to $3/4$ inch diameter.
- Motor housing and volute are generally constructed of cast iron.
- Motors are oil filled for operating under submerged conditions.

- Impellers are normally open or semi-open vane type and constructed of ductile iron or high-strength thermoplastics.
- Effluent pumps will typically handle pressure heads up to 120ft and flows out to 150 gpm.
- The primary usage is to pump septic tank effluent to pressure sewers, sand filters, drainfields, mound systems, etc.

Advantages:

1. Provide a relatively inexpensive method of pumping high volumes of effluent.
2. Pumps and parts are readily available and easy to service or replace.

Disadvantages:

1. Cast iron construction is susceptible to rapid corrosion; baked on epoxy paints only provide limited protection (*anticipated life 8 to 10 yrs.*)
2. Heavy (40 to 90 lbs.), often requiring an expensive or awkward lifting mechanism for safety and ease of maintenance.
3. In most applications high flows are not necessary, and unless good design techniques are followed, can result in improper operation of the system, or cause premature motor failure. Flow control orifices are sometimes used to restrict the discharge rate.
4. Because of limited pumping heads and large cost differentials between models, models ranging from $1/4$ to $1\frac{1}{2}$ Hp may need to be inventoried and detailed records kept of each installation.

Submersible Turbine Pumps:

- Pump size ranges from $1/2$ to $1\frac{1}{2}$ Hp; 115 VAC when $1/2$ Hp or less, 230 VAC when $3/4$ Hp or greater; 2 Hp and larger models are also available, however they generally require special control considerations to ensure that adequate starting torque is provided.
- Solids handling capacity ranges from $1/8$ inch to $1/4$ inch diameters.
- Motor housing, liquid-end and discharge assembly are generally constructed of stainless steel, bronze and thermoplastic materials.
- Motors are encapsulated with a special thermosetting resin and hermetically sealed in corrosion resistant stainless steel casings for maximum protection from moisture while operating under submerged conditions.
- Impellers are closed-vane type located in a fixed diffuser and stacked in stages inside a stainless steel or thermoplastic casing. The impellers and diffusers are generally constructed of high strength thermoplastic or stainless steel.
- Residential type turbine pumps are capable of handling pressure heads up to 500 feet \pm and flows out to 100 gpm \pm (A typical $1/2$ Hp model will deliver 5 gpm at 200 feet of TDH).
- The primary usage is to pump septic tank effluent to pressure sewers, sand filters, drainfields, mound systems, etc.

Advantages:

1. 300 series stainless steel and thermoplastic construction make turbine effluent pumps well suited for corrosive or abrasive environments (*anticipated life 30 years \pm*).
2. Inexpensive method of pumping septic tank effluent.
3. Pumps and parts are readily available and easy to service or repair.
4. Light weight construction (25 to 45 lbs.) allows for safety and ease of maintenance.

5. Ideal for applications requiring steep pump curves; in most applications high flow rates are undesirable and selection of a single pump capable of maintaining low flows through a large TDH range (i.e. 5 to 9 gpm between 160' and 10' of TDH) simplifies design, inventory, and maintenance. Flow control orifices are sometimes used with a high head pump to steepen the curve even more.
6. Low operating cost.
7. Extended warranty periods are available (5 yrs).

Disadvantages:

1. Limited solids handling ability.

In typical well pump applications handling of sandy or abrasive water is not uncommon, “Abrasion-Resistant Construction” is an industry standard in the design and fabrication of quality submersible turbine pumps. Water passages are designed specifically to permit handling of abrasive fluids and have been quite successful for many years in pumping extremely harsh liquids, such as landfill leachate. At work in a septic tank, a submersible pump is not called upon to handle anything nearly as abrasive as the landfill leachate. In fact, since the septic tank functions effectively as a degritting chamber and primary clarifier, the effluent pumped is essentially free of sand and heavy particles which have settled out.

Turbine pumps are typically used with septic tank effluent filters or screened pump vaults. The size and orientation of the vault’s inlet ports enhances the protection against solid materials entering the pump vault, with absolute protection against large particles. Effluent quality is significantly enhanced; dosing applications, in many states and other countries, require some prefiltering mechanism to protect orifices from clogging and improve overall system performance.

Electrical Requirements

Electrical testing of an effluent pump should be during initial installation, troubleshooting, and routine maintenance calls. The only equipment needed is a clamp-on ammeter.

The common pump motors used in onsite applications are single phase, with a frequency of 60 cycles per second (60 Hz) and may be either 115 or 230 volts. This is the most readily available source of power in the U.S. Older residences may not have 230 VAC power available.

While working with electrical circuits, extreme caution should be practiced. A qualified electrician should be employed to perform the electrical work. Insure that ground connections are secure and proper, and that the installation complies with National Electric Code (NEC) requirements. For detailed electrical information, refer to manufacturer’s literature. Contact local regulatory agencies for local reference to rules and policies.

Electricians, however, are not required to be trained or knowledgeable about the biological or hydraulic processes occurring in the tanks, sand filters, drainfields, or the effect the control system has on performance. Familiarity with the design functions should be as much a requirement as familiarity with proper electrical wiring technology; without both it’s unreasonable to expect more than partial correctness in the finished product. In some locations, general contractors or operators are allowed to perform a limited amount of wiring because of their overall training, knowledge, and familiarity with their onsite installations. This limited license allows them to wire the sensors and

pumping equipment to the control/alarm panel; the electrician provides the power supply to the panel. To acquire a limited electrical license, special certification by the local electrical authority is generally required.

Monitoring

For any system to operate smoothly, every possible problem should be anticipated. In preparing for an effective preventive maintenance program, a thorough list of potential problems, causes, and their corrective action is essential. The use of counter and hour meter data will aid in identifying problems and remedying them before failure occurs. Table 2 has been prepared as a general guide for evaluating hour meter and counter readings for troubleshooting.

A. Typical Ranges

Normal counts; 1 to 8 per day when pumping on-demand, but may be as often as 4 times an hour in programmable timer applications.

Normal pumping time; 20 seconds to 10 minutes per cycle.

Normal pumping time; 1 to 40 minutes per day.

B. Probable Causes of recorded occurrences higher or lower than expected

1. High water usage or occupancy.
2. Low water usage or vacancy.
3. Pump oversized.
4. Pump undersized, clogged impeller or plugged service line.
5. Infiltration (*tank, building sewer, riser, etc.*).
6. Actual level control differential greater than design.
7. Actual level control differential less than design.
8. Level control sticking on.
9. Check valves not seating properly.
10. Siphoning (*in or out*).
11. Exfiltration (*tank, building sewer*).
12. Service line break.
13. Faulty meter, incorrect reading, incorrect recording, or miscalculation.
14. Programmable timer setting is incorrect.

Table 2: Guide to Meter and Counter Readings, and Common Problems

Probable cause 13 is common to any meter reading combination. There are also mixtures of the general causes that may produce a certain meter reading combination. The operator must rely on his best judgment to isolate the problems.

Regulations

Septic tanks have not been declared specifically by reference in either the NEC or ANSI/NFPA 70-1984 publications as hazardous locations. *The National Fire Protection Association*, through technical committees, assesses hazards and provides guidance specific to wastewater in their document NFPA 820, which does not classify single family residential applications —5 or fewer— as hazardous. As for federal regulation, the EPA has stated in Appendix H, Section A-7 of its 1985 Construction Grant Document for Municipal Wastewater Treatment, that residential pumping units associated with onsite

wastewater treatment and conveyance of wastewater from individual dwelling units or clusters are **exempt** from its guidance requirements for hazardous locations. Therefore, they do not require intrinsically-safe controls for anything other than general wiring methods. All studies and investigations to date demonstrate conclusively that gases are well vented from the septic tank, through the building sewer lines and vent. Consequently, most state and regulatory agencies do not exact hazardous requirements for onsite septic tank effluent pumping, or have reduced restrictions. Class I, Division 2 (low hazard) is the most restrictive guidelines usually assessed.

Pumping systems will typically comply with the Class I, Division 2 classification by satisfying the following requirements:

1. Float switches are hermetically sealed (they are fused to maintain buoyancy and the mercury or mechanical switching capsule is fused to maintain the integrity of the switch), thus satisfying the requirement for low-hazard, naturally vented wet wells.
2. A redundant off float switch may be required to insure submergence of the motors; turbine pumps by the nature of their construction insure submergence since the motors are located below the liquid handling end.
3. The motor cord is listed in accordance with the NEC for extra-hard usages (SO).
4. A conduit seal for electrical cords is provided following the riser.

For large or commercial flow applications, intrinsically safe circuitry and wiring methods are normally required.

National Electric Code (NEC)

The *National Electric Code* provides guidance for electrical safety for many countries. The *National Electric Code*, revised every three years, regulates electrical systems and their usage by every person in this country who plugs in a radio, turns on a light, or installs a pump. From general household circuitry to classified hazardous circuitry, the *National Electric Code* is the most widely adopted code in the world with over 1,000,000 editions distributed. The *National Electrical Code Handbook* is published by the *National Fire Protection Association*. The NEC is also endorsed by the *American National Standards Institute* (ANSI). The code is purely advisory as far as the *National Fire Protection Association* and *American National Standards Institute* are concerned, but is offered for use in law and regulatory purposes in the interest of life and property protection. Regulatory agencies normally adopt the *National Electric Code* in its entirety, but will enact by rule, supplemental policies or procedures based on local practices, specific products, or interpretations. The *National Electric Code* may not specifically classify an item or an area, but will reference ANSI, NFPA, or other standards that provide the appropriate coverage.

National Fire Protection Association (NFPA)

The *National Fire Protection Association*, through technical committees, assesses hazards and provides guidance relating to safeguard of the products of combustion. Specific to wastewater is their document NFPA 820, "Recommended Practice for Fire Protection in Wastewater Treatment and Collection Facilities." The *National Fire Protection Association's* documents are "recommended practice" referred to by the NEC and adopted by other regulatory agencies. Enforcement, though, of NFPA's recommended practices is the responsibility of the certifier. The technical committees work full time upgrading and amending the codes. As soon as they complete each code revision the next revision process begins.

Listing

State and local agencies normally require that electrical appliances and individual components be listed or recognized with an approved testing and accrediting agency. Two of the most common are UL and CSA. Before a product receives its seal from one or more listing agency, it must first withstand rigorous testing and engineering evaluations. Approvals, depending on the complexity of the product, may take more than a year to complete. Listing agencies periodically inspect manufacturing facilities to ensure product compliance. Listing agencies also revise product approvals keeping them current with *National Electric Code* changes.

Accrediting agencies list products for specific as well as general applications; pumps for instance, used in effluent or sewage application must clearly be designated for that usage.

CSA standard and UL standard 778, for “motor operated water pumps”, cover the requirements of approved listings for a number of motor operated pumps, intended to be used in ordinary locations, in accordance with the National Electric Code, NFPA 70. Typical pumps covered under these listings are: deep well pumps, effluent pumps, irrigation pumps, jet pumps, sewage pumps, sump pumps, and several others. Under these guidelines, the pump construction shall employ materials found by investigation to be acceptable for the intended application; the intended applications being: a) submersible or b) non-submersible. Encapsulated watertight components (e.g. Franklin’s, stainless steel, 4-inch diameter, lightning protected motor) provide a durable, protective, enclosure that does not require additional corrosion proofing. The required protection against corrosion addresses many concerns and takes many precautions (especially with steel and cast iron motor enclosures) to insure acceptability, reliability, and performance.

SUMMARY

The control/alarm features and pump selections are as important to the reliability and performance of the onsite system as watertight tanks. The simplicity in float assemblies or arrangements ensures ease of installation, maintenance, cost effectiveness of the system and improves the reliability of the operation. Using a programmable timer provides a method of dosing that enhances the quality and consistency of treatment, adds some assurance that excessive discharges will be detected, elevates the awareness of the user, and improves the cost effectiveness of the installation. The quality of the pumps and the discharge control play an equal role in system performance and ease of maintenance. All systems, regardless of their complexity, must be constructed and installed with pride and concern for ease of maintenance.

References

1. Dunbar, Prof. Dr. 1988. Principles of Sewage Treatment. Charles Griffin & Co., Ltd., London, England.
2. Dymond, R. L. (1981), “Design Considerations for the Use of On-Site Sand Filters for Wastewater Treatment,” Master’s Thesis, Department of Civil and Environmental Engineering, Pennsylvania State University.
3. Laak, Rein. 1980. Wastewater Engineering Design for Unsewered Areas. Ann Arbor Science Publishing /The Butterworth Group, Ann Arbor, Michigan.

4. Mohammed, A. (1991), "Performance of Intermittent Sand Filters: Effects of Hydraulic Loading Rate, Dosing Frequency, Media Effective Size, and Uniformity Coefficient," Master's Thesis, Department of Civil and Environmental Engineering, University of California, Davis.
5. U.S. Environmental Protection Agency (1977), Alternatives for Small Wastewater Treatment Systems: On-Site Disposal/Septage Treatment and Disposal, EPA 625/4-77-001 (Vol. 1), U.S. EPA, Cincinnati, OH.
6. Winneberger, John Timothy , Ph.D. 1977. Consultant, Septic tank systems, personal communication titled Interceptor tank design.
7. Tchobanoglous, George, University of California, Davis (1995), personal communications.