

# AX25RT Treatment System - Pump Discharge

Filter Tank Dry Weight: 950 lbs

## Design Notes

For residential strength waste up to 6 bedrooms.

Installation to be performed by an AdvanTex Authorized Installer only.

Start-up and service to be performed by an AdvanTex Authorized Service Provider only.

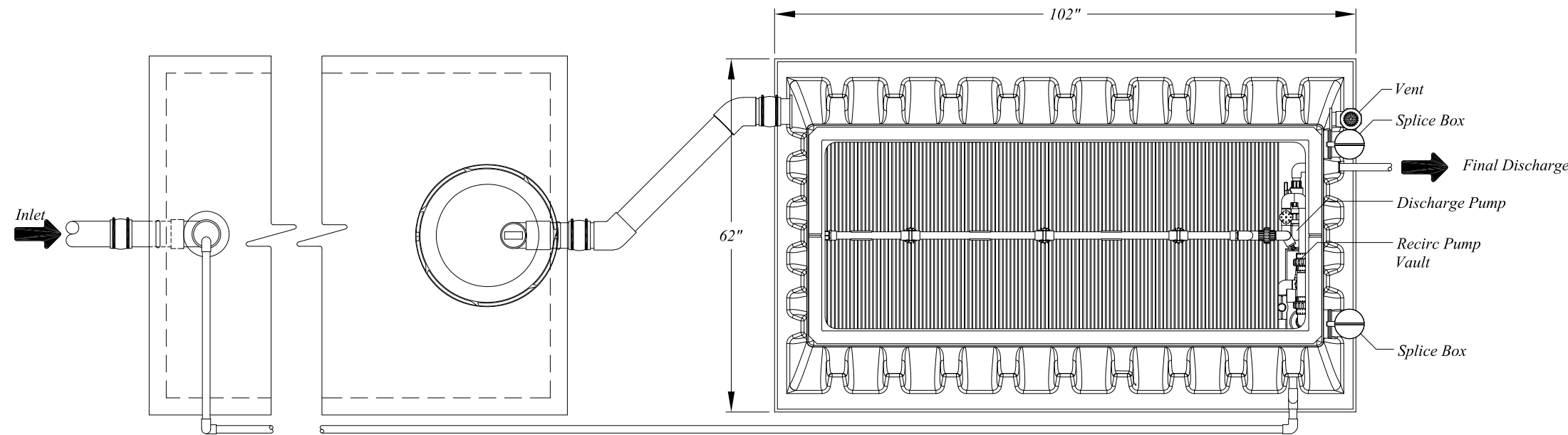

\* Primary Tank - Top View

AX25 800 gal. Recirc. Tank - Top View

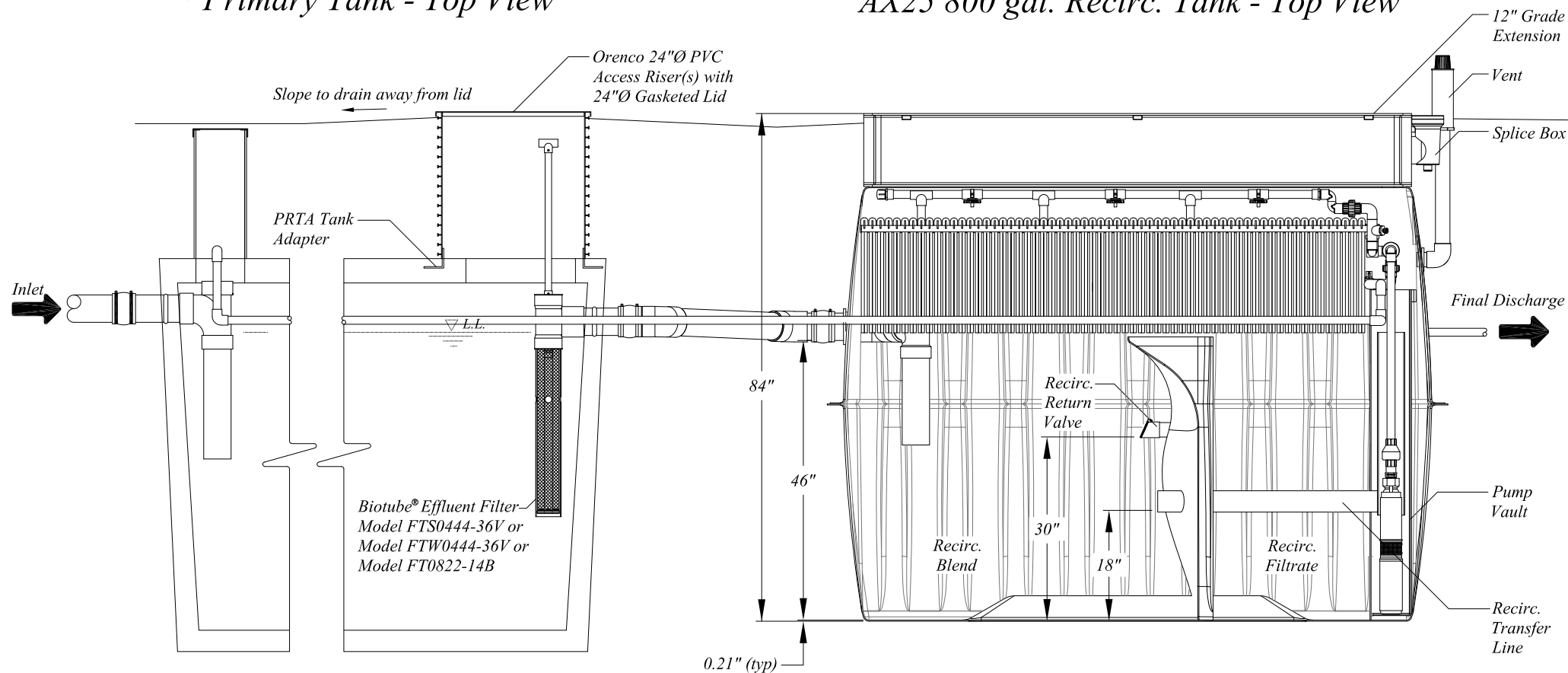
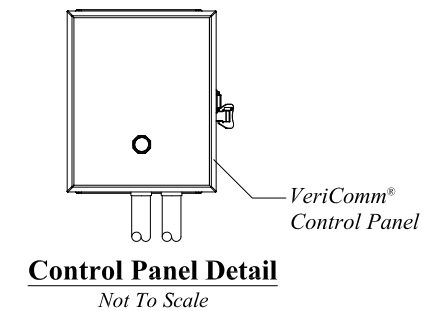

\* Primary Tank - Side View

AX25 800 gal. Recirc. Tank - Side View

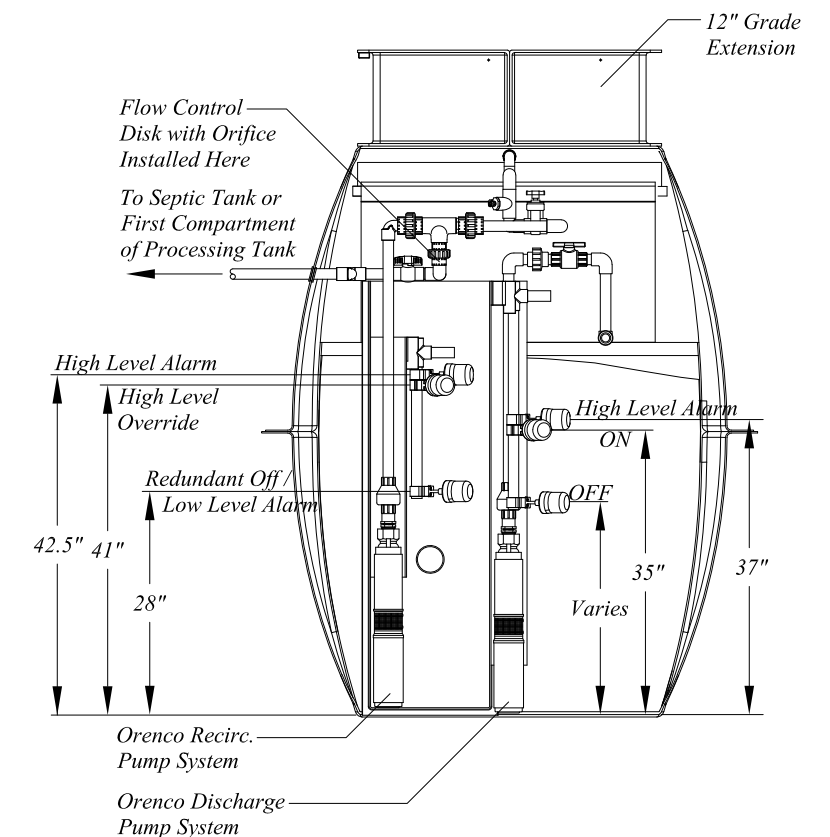

Discharge Chamber - End View

\* 1,250 Gallons minimum capacity for 5 bedrooms  
1,500 Gallons minimum capacity for 6 bedrooms.



© Orenco Systems, Inc.  
Portions or all of this Proposed System Configuration Drawing, as appropriate, may be reproduced and integrated into the site-specific layout and configuration of a system by its designer.

**Disclaimer:** This Proposed System Configuration Drawing is provided solely as a design aid and illustrates one possible configuration of a system that would comply with Orenco's design criteria for the requirements and/or specifications that have been communicated to Orenco (based on third-party standards testing protocols and performance reports, as applicable). Design decisions, including the actual layout and configuration of the system and its viability for the project, are at the sole discretion of the systems's designer.

AX25RT Mode 3B  
with 12" Grade Extension

Details

Drawn By: BAS

Reviewed By: AY

File: NDW-ATX-RT-STD-47.DWG

Scale: 1" = 2'-0"

Sheet: 1 OF 1

Rev: 1.0 Date: 10/04/2018