

# AX25RT Treatment System - Pump Discharge

## Design Notes

For residential strength waste up to 6 bedrooms.

Installation to be performed by an AdvanTex Authorized Installer only.

Start-up and service to be performed by an AdvanTex Authorized Service Provider only.

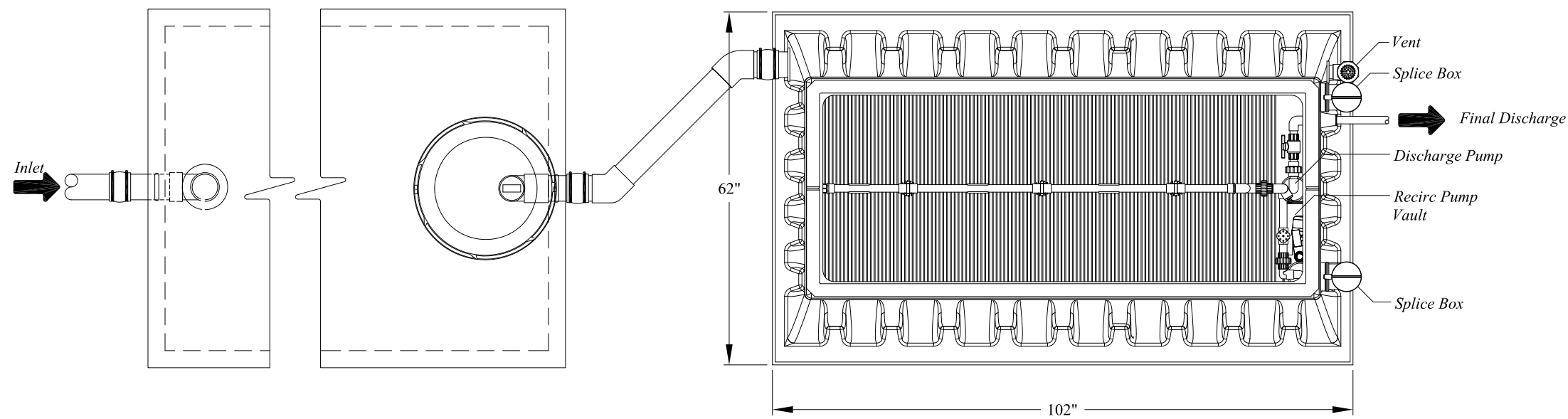

\* Primary Tank - Top View

AX25 800 gal. Recirc. Tank - Top View

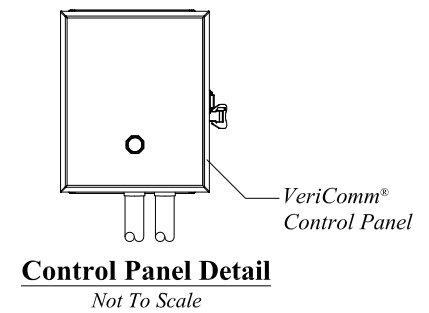

Control Panel Detail

Not To Scale

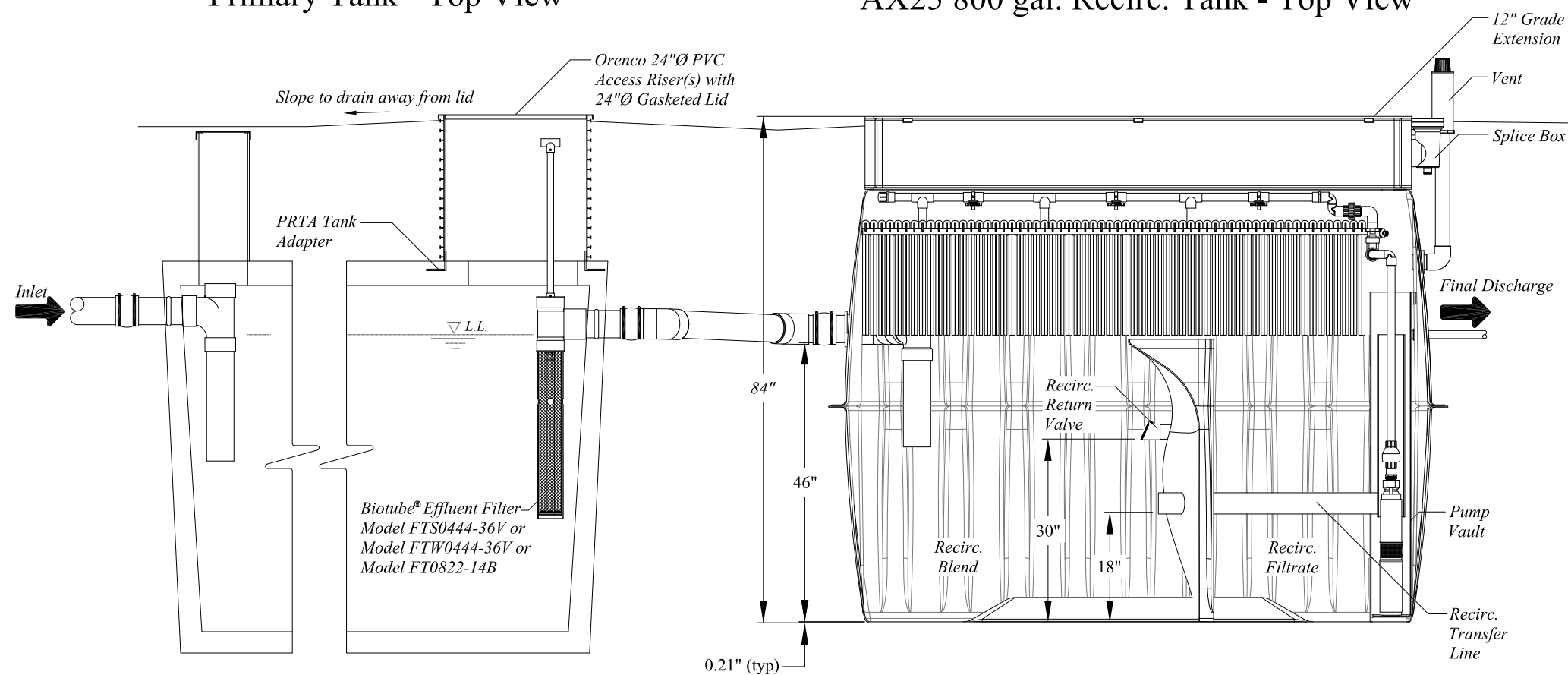

\* Primary Tank - Side View

AX25 800 gal. Recirc. Tank - Side View

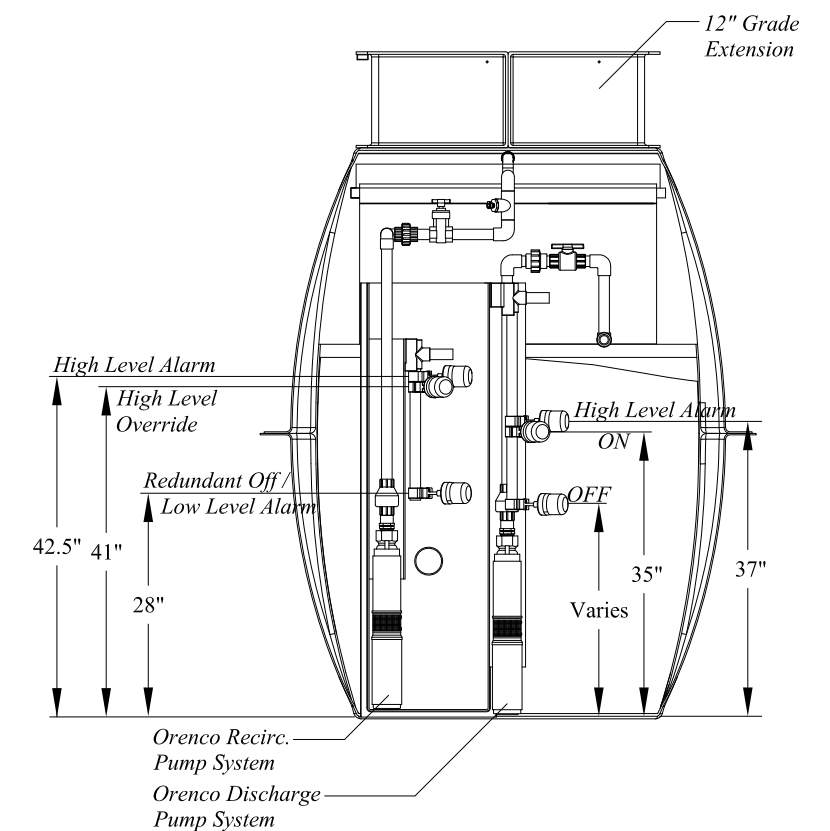

Discharge Chamber - End View

\* 1,250 Gallons minimum capacity for 5 bedrooms  
1,500 Gallons minimum capacity for 6 bedrooms.

Copyright © 2015  
Orenco Systems®, Inc.

### UNAUTHORIZED CHANGES & USES

Orenco has prepared these drawings for use by the design engineer. Orenco will not be responsible or liable for unauthorized changes to or uses of these drawings. All changes to these drawings must be made in writing and must be approved by the design engineer.

PRODUCT CONFIGURATION DRAWINGS

**Orenco**<sup>®</sup>  
Orenco Systems<sup>®</sup>, Incorporated

Drawn By: BEN SMITH

Drawn For:

Project: AX25RT Mode 1B  
with 12" Grade Extension

Title: NDW-ATX-RT-STD-33

Scale: 1" = 2'-0"

Sheet: 1 OF 1

Rev: A-01 Date: 7/23/2015