

AX20RT Treatment System - Pump Discharge

Filter Tank Dry Weight: 900 lbs

Design and Installation Notes

- For Expected Flows 4 Bedrooms or less
- Installation To Be Performed By An AdvanTex Trained Installer Only
- Start-up And Service To Be Performed By An AdvanTex Trained Service Provider

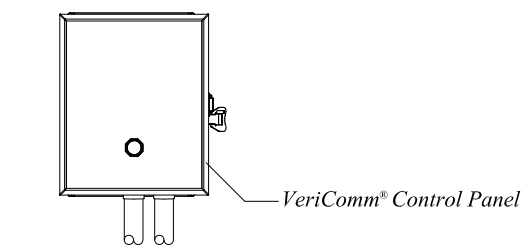
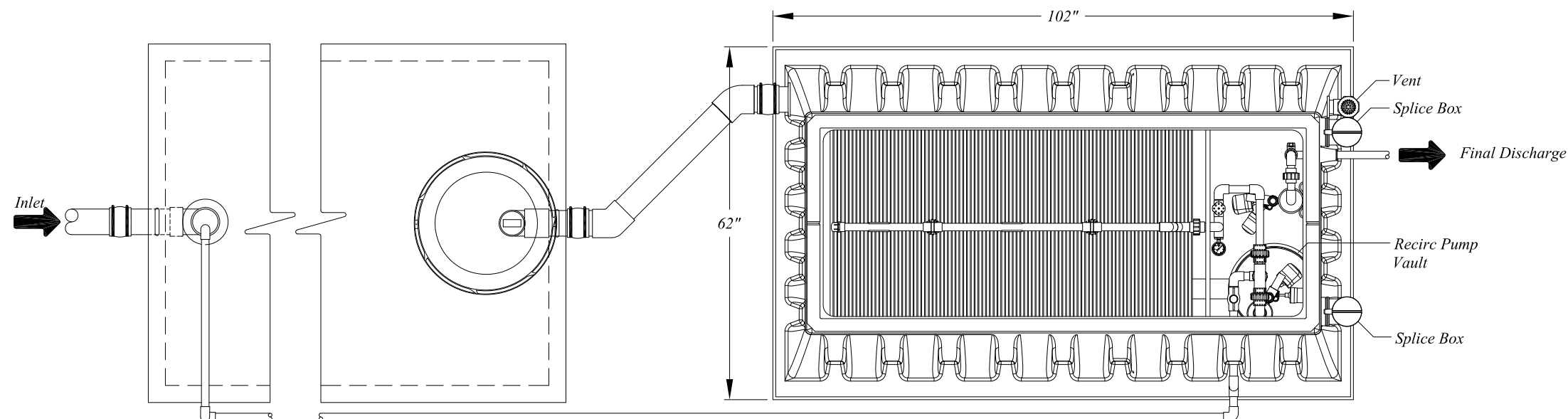

Control Panel Detail
Not To Scale

1000 gal. Primary Tank - Top View

AX20 800 gal. Recirc. Tank - Top View

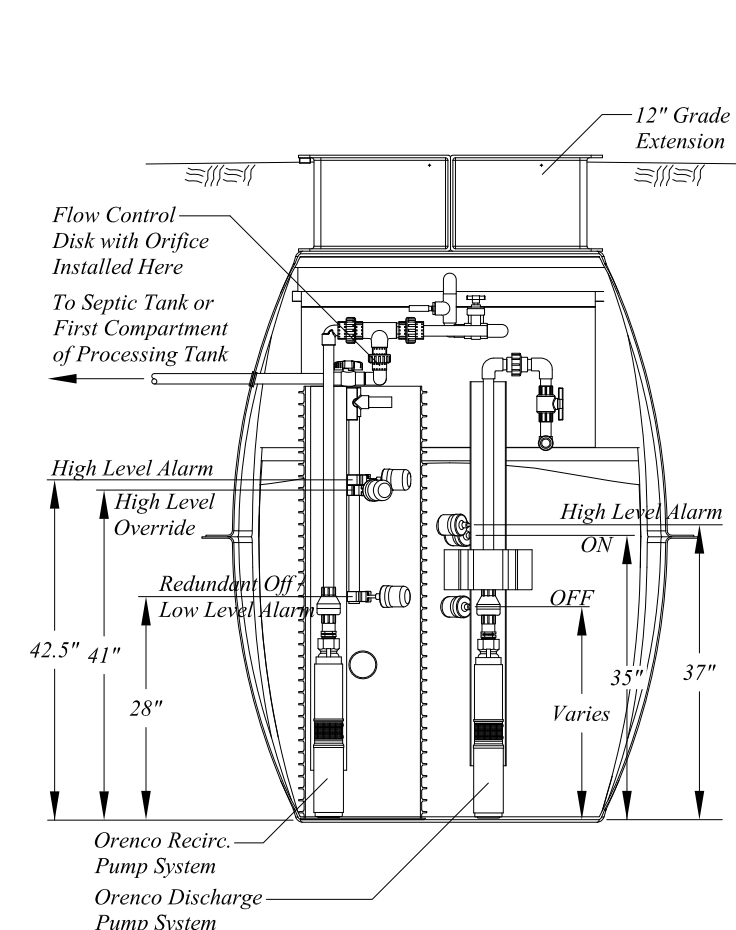
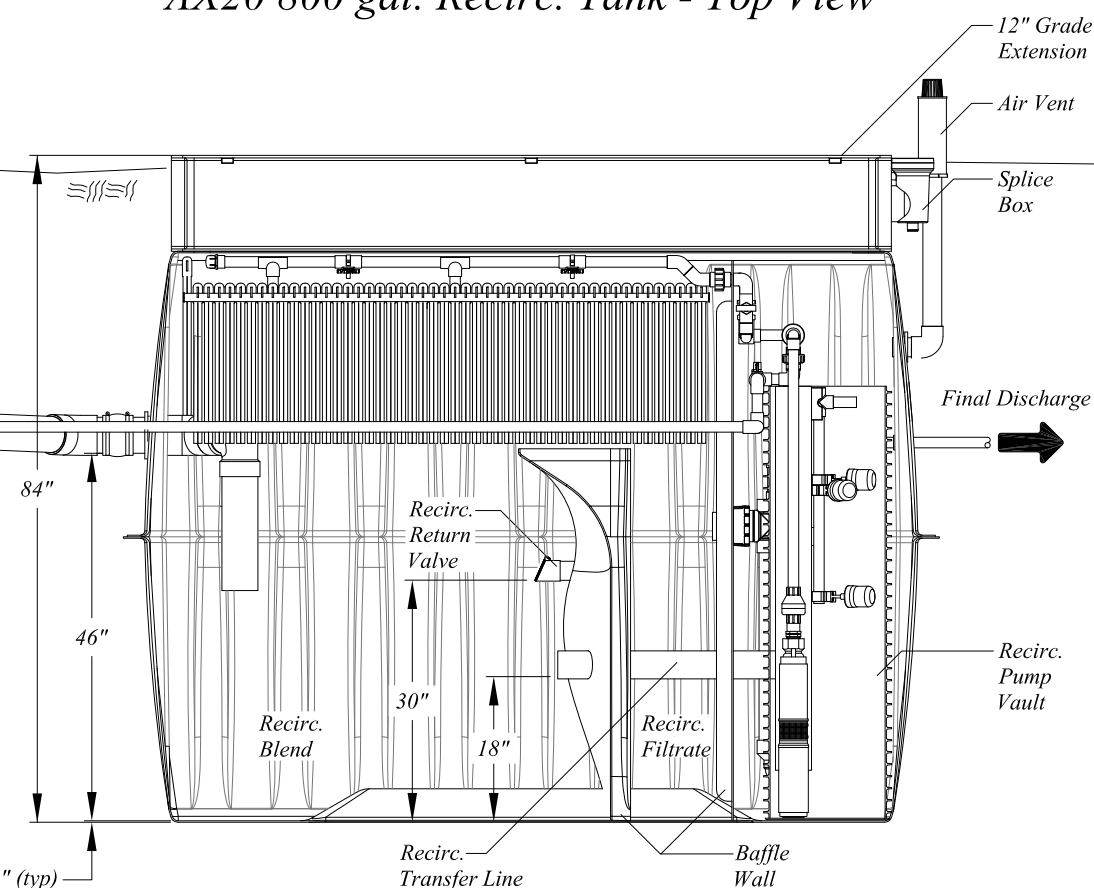
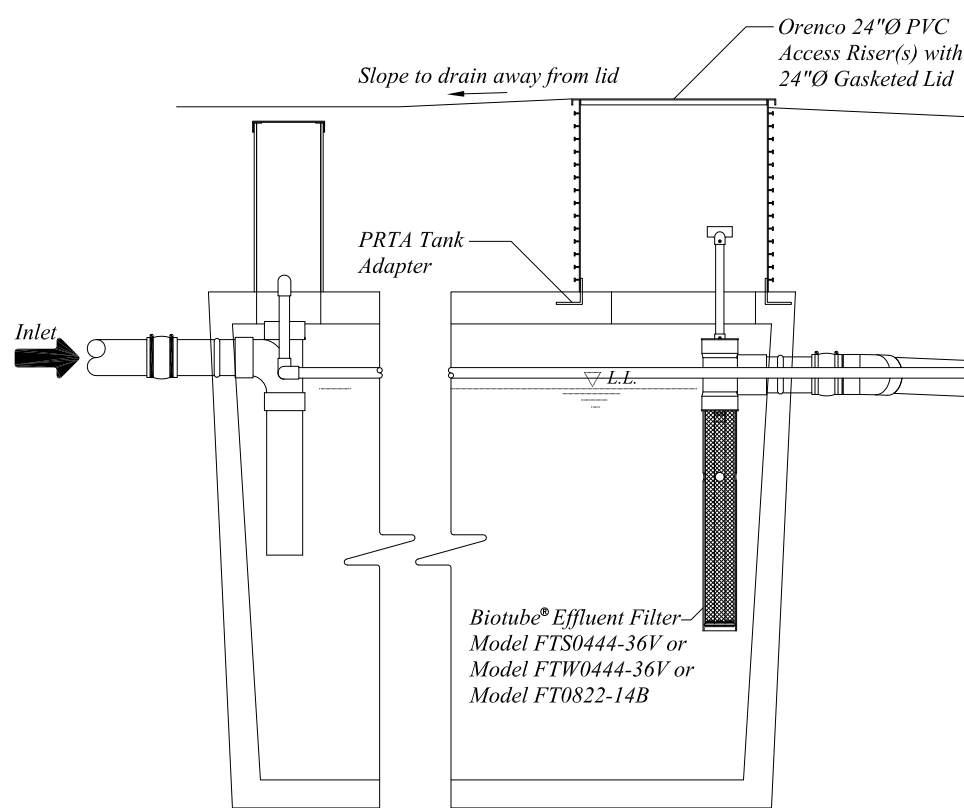

1000 gal. Primary Tank - Side View

AX20 800 gal. Recirc. Tank - Side View

Discharge Chamber - End View



© Orenco Systems, Inc.
Portions or all of this Proposed System Configuration Drawing, as appropriate, may be reproduced and integrated into the site-specific layout and configuration of a system by its designer.

Disclaimer: This Proposed System Configuration Drawing is provided solely as a design aid and illustrates one possible configuration of a system that would comply with Orenco's design criteria for the requirements and/or specifications that have been communicated to Orenco (based on third-party standards testing protocols and performance reports, as applicable). Design decisions, including the actual layout and configuration of the system and its viability for the project, are at the sole discretion of the systems's designer.

AX20RT Mode 3B
With 12" Grade Extension
System Details

Drawn By: BAS	Scale: 1" = 4'-0"
Reviewed By: AY	Sheet: 1 OF 1
File Name: NDW-ATX-RT-STD-4I.DWG	Rev: 1.0 Date: 9/19/2017