

- NOTES:
1. INVERT DIMENSION FROM TANK I.D.
 2. ROTATE SHIPMENT ON TRAILER.
 3. ESTIMATED TANK WEIGHT: 4,200 lbs.

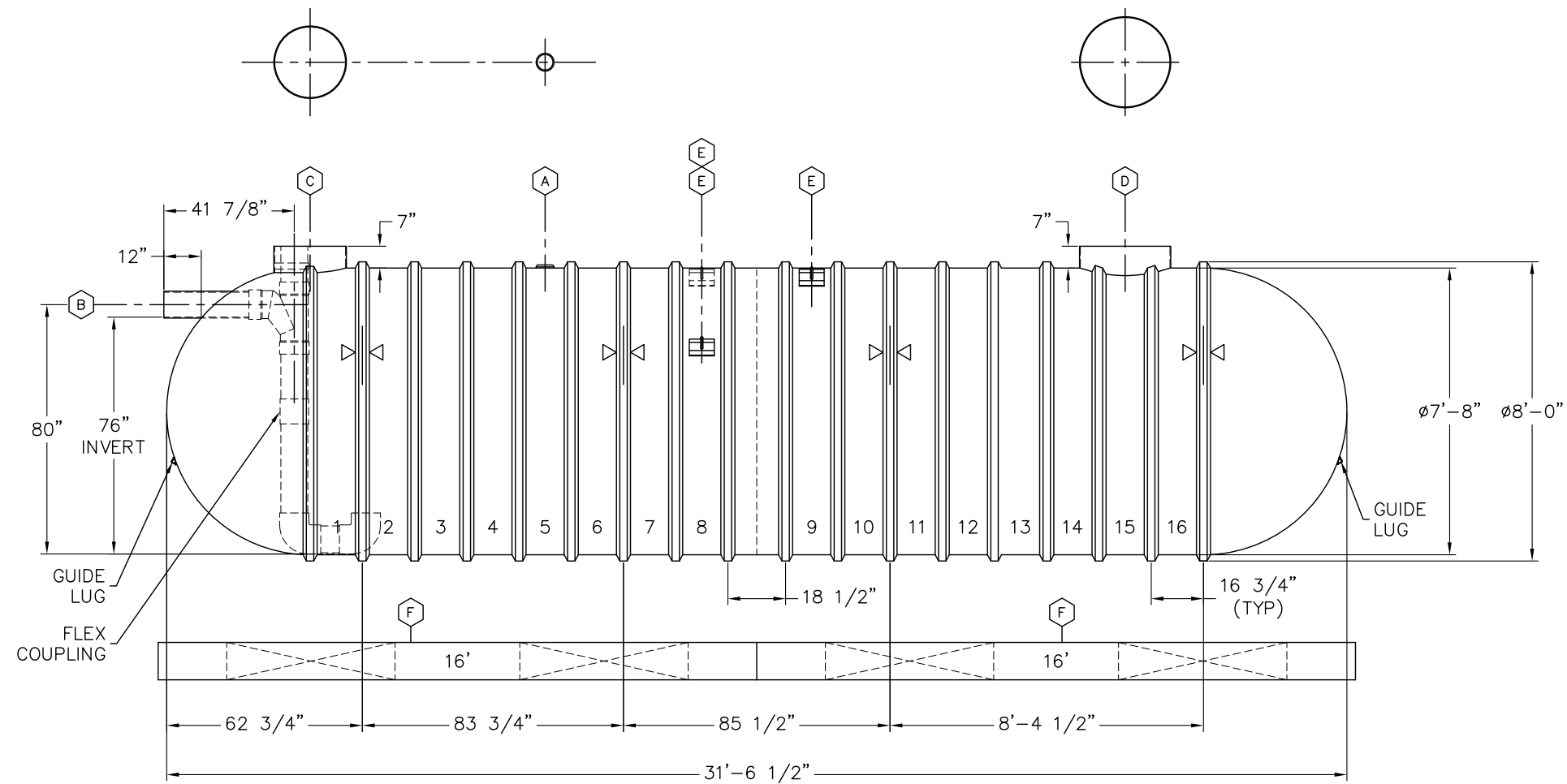

ITEM	QTY	DESCRIPTION
(A)	1	4"NPT SERVICE FITTING
(B)	1	8"DIA SCH 40 PVC INLET PIPE, INTERNAL SANITARY TEE & PIPES WITH SMOOTHING INLET & FLEXIBLE COUPLING
(C)	1	RISER PIPE, 23 3/8"O.D., FOR 24"(NOMINAL) ACCESS OPENING
(D)	1	RISER PIPE, 29 3/8"O.D., FOR 30"(NOMINAL) ACCESS OPENING
(E)	3	LIFTING LUG (10" x 8") 17", 17", 34"
(F)	4	16' PREFABRICATED CONCRETE DEADMEN
▷◁	4	HOLD DOWN STRAP LOCATION

CUSTOMER DESIGNATION:
RAINWATER CISTERN

00		REVISION DESCRIPTION			
DRN	DATE	CHK'D	DATE	APPR'D	DATE
XERXES BY SHAWCOR					
DRN	DATE	TITLE			
LJB	3-3-21	8' DIA SW			
CHK'D	DATE	CAP. 10,000 GALLONS			
PWM	3-3-21	BIO SOLUTIONS			
APPR'D	DATE	DR. SIZE	DR. NUMBER	REV	
-	-	B	668-370	00	
SALES MANAGER		SCALE:	SHT 1 OF 1		
DAVID HOLMES		N.T.S.			
INDUSTRY TYPE: M204 WATER COLLECTION AND CONSERVATION					