

NOTES:

1. INVERT DIMENSION FROM TANK I.D.
2. 14' PREFABRICATED CONCRETE DEADMEN ANCHOR POINTS ARE NOT SYMMETRICAL. NOTE THE POSITIONING WHEN INSTALLING.
3. ESTIMATED TANK WEIGHT: 6,600 lbs.

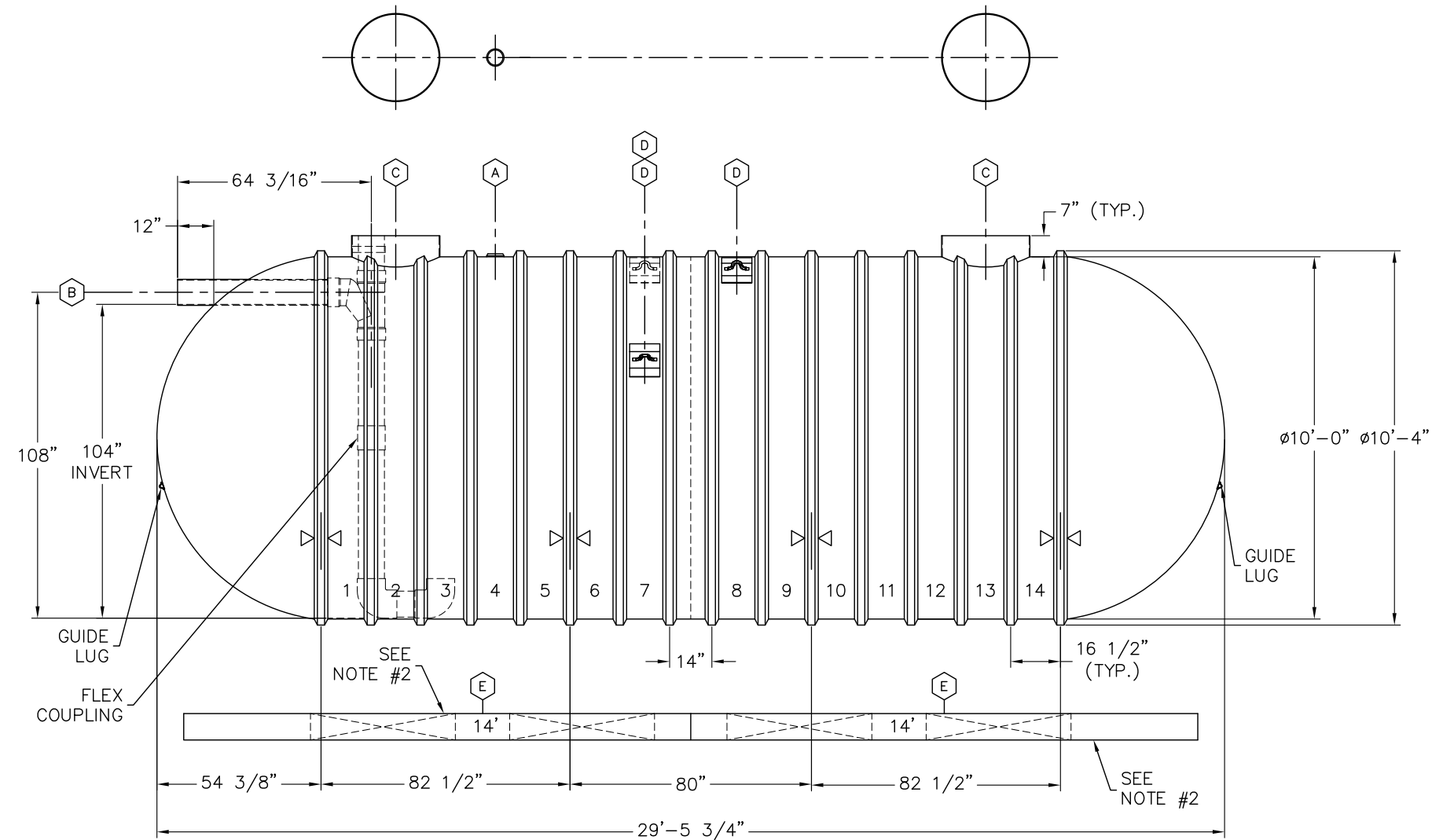

ITEM	QTY	DESCRIPTION
(A)	1	4"NPT SERVICE FITTING
(B)	1	8"DIA SCH 40 PVC INLET PIPE, INTERNAL SANITARY TEE & PIPES WITH SMOOTHING INLET & FLEXIBLE COUPLING
(C)	2	RISER PIPE, 29 3/8"O.D., FOR 30"(NOMINAL) ACCESS OPENING
(D)	3	LIFTING LUG (12" x 10") 22.5", 22.5", 45"
(E)	4	14' PREFABRICATED CONCRETE DEADMEN
▷◁	4	HOLD DOWN STRAP LOCATION

CUSTOMER
DESIGNATION:
RAINWATER CISTERN

00		REVISION DESCRIPTION			
DRN	DATE	CHK'D	DATE	APPR'D	DATE
XERXES BY SHAWCOR					
DRN	LJB	DATE	3-3-21	TITLE	10' DIA SW
CHK'D	PWM	DATE	3-3-21	CAP.	15,000 GALLONS
APPR'D	-	DATE	-	BIO SOLUTIONS	
SALES MANAGER	DAVID HOLMES	DR. SIZE	B	DR. NUMBER	668-367
SCALE:	N.T.S.	REV	00	SH T	1 OF 1
INDUSTRY TYPE: M204 WATER COLLECTION AND CONSERVATION					