

Control Panel Wiring Diagram

Model VCOM-S2 RO



814 AIRWAY AVENUE
SUTHERLIN, OREGON
97479-9012

TELEPHONE:
(800) 348-9843
(541) 459-4449

WEBSITE:
www.orenco.com

Key

- = Factory Wire
- - - = Field Wire
- · - · = Alternate Field Wire
- A = Audio Alarm, 115 VAC
- AL = Alarm Light
- AS = Audio Silence Switch
- CCB = Controls Circuit Breaker
- DF = Fuse, 120VAC/1A
- M = Motor Contactor
- PCB = Pump Circuit Breaker
- PSA = Phone Line Surge Arrester
- PSC = Power Supply Cord (24VDC)
- RTU = ATRTU-100 Controller
- TL = Terminal Link
- TR = Transformer 120-36/18VAC

*Options

- HT = Heater
- PL = Power Light
- PRL = Pump Run Light
- SA = Surge Arrester

Remote Alarm Connections

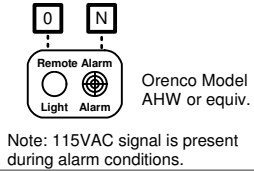

Terminal Block Types



For VCOM-S RO operation description, see drawing no. "EIN-CP-OP-498".

Power Wiring Options

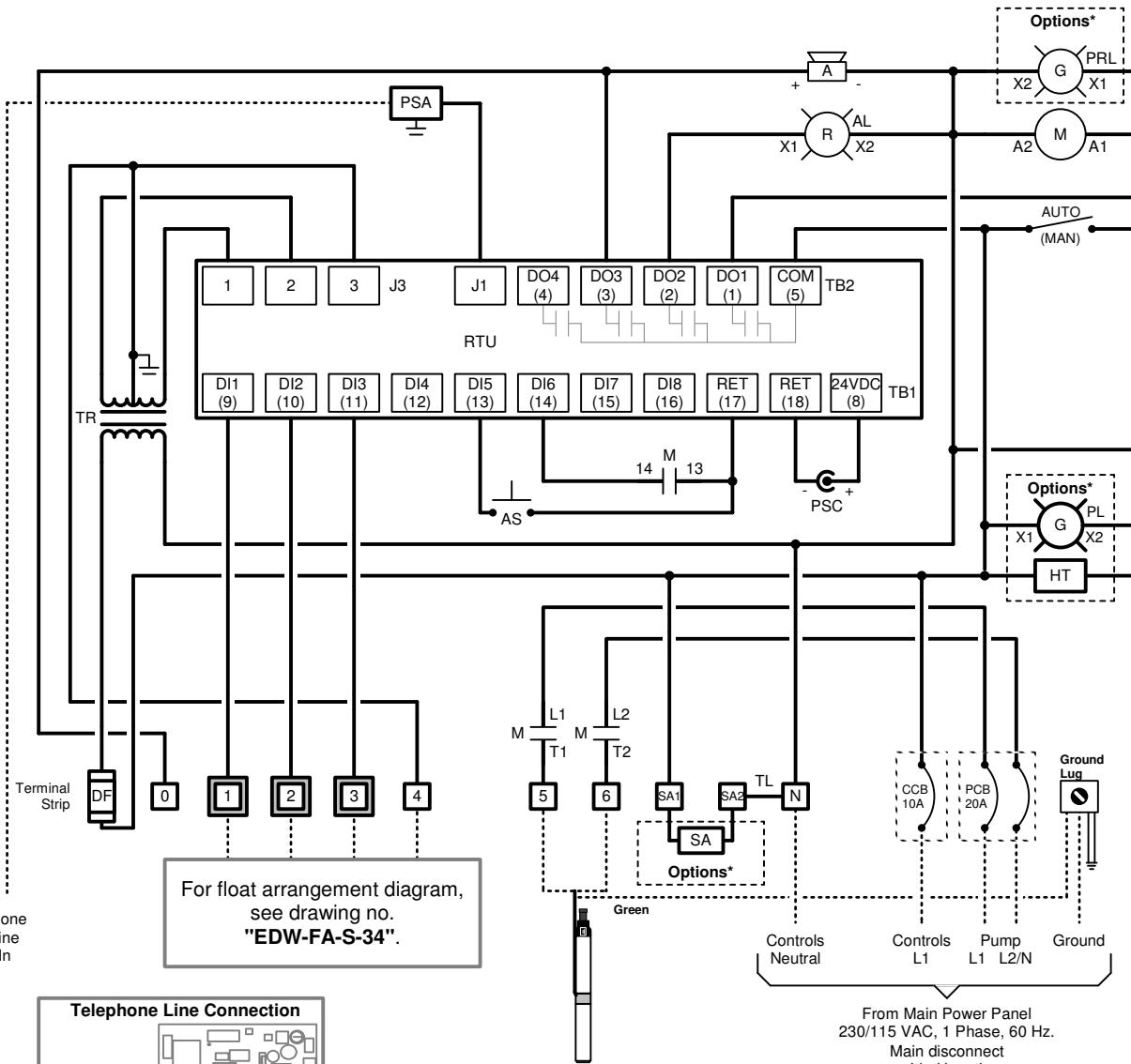
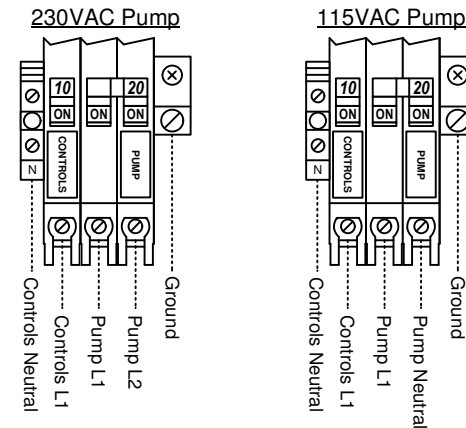

For float arrangement diagram, see drawing no. "EDW-FA-S-34".

Telephone Line Connection

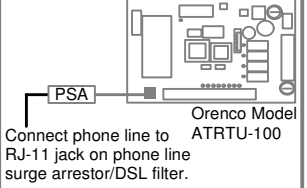

Connect phone line to RJ-11 jack on phone line surge arrester/DSL filter.

Pump
230 VAC / 3 Hp.
115 VAC / 1 Hp.
1 Phase / 60 Hz.

NOTE: Motors must have internal overload protection

From Main Power Panel
230/115 VAC, 1 Phase, 60 Hz.
Main disconnect provided by others.