

Control Panel Wiring Diagram

Model VCOM-S2 PT RO SA

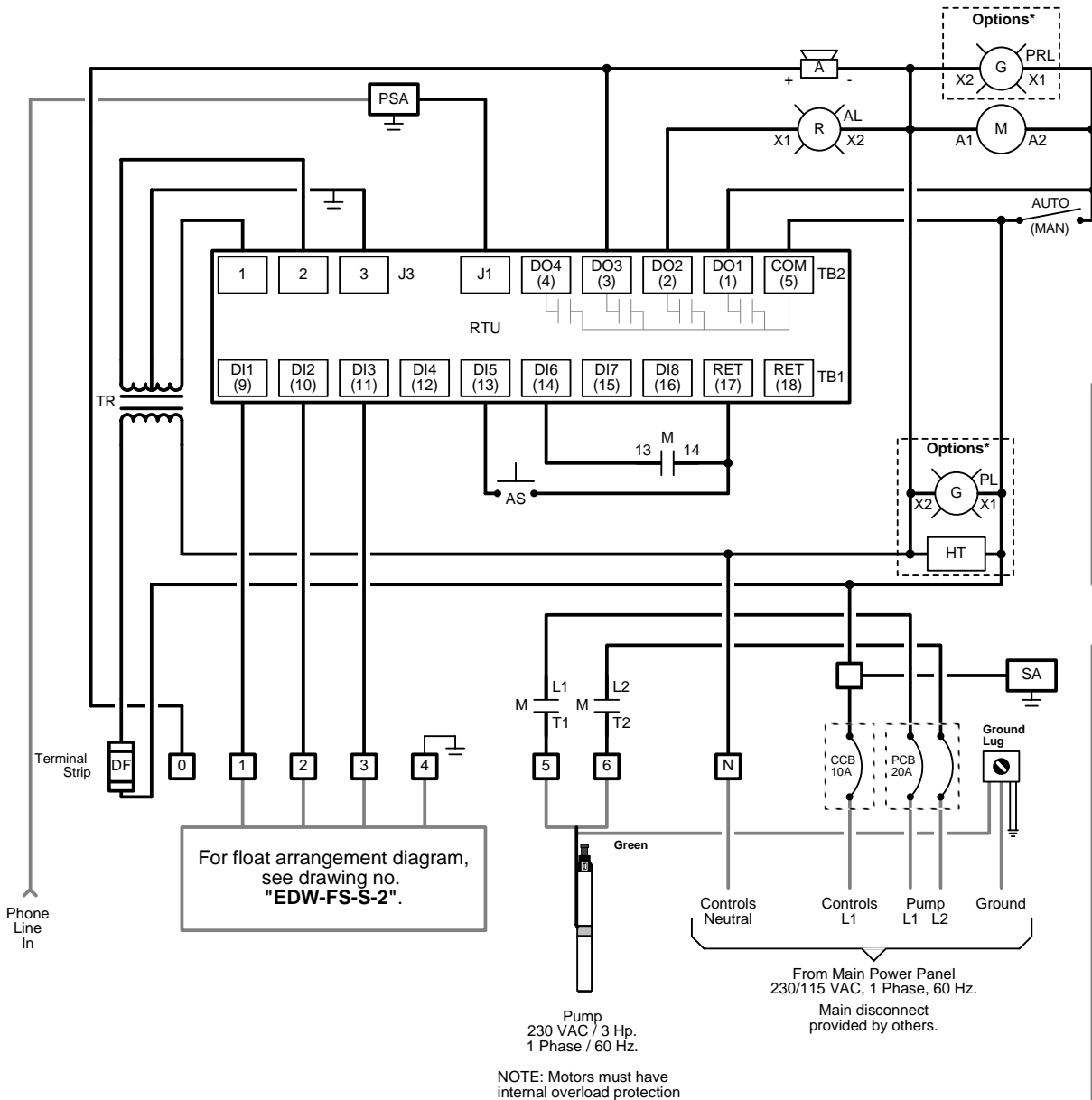

For float arrangement diagram,
see drawing no.
"EDW-FS-S-2".

NOTE: Motors must have
internal overload protection

Key

- = Factory Wire
- - - = Field Wire
- · - · = Alternate Field Wire
- A = Audio Alarm, 115 VAC
- AL = Alarm Light
- AS = Audio Silence Switch
- CCB = Controls Circuit Breaker
- DF = Fuse, 120VAC/1A
- M = Motor Contactor
- PCB = Pump Circuit Breaker
- PSA = Phone Line Surge Arrester
- RTU = ATRTU-100 Controller
- SA = Surge Arrester
- TL = Terminal Link
- TR = Transformer 120-36/18VAC

- *Options**
- HT = Heater
 - PL = Power Light
 - PRL = Pump Run Light

For VCOM-S PTRO
operation description,
see drawing no.
"EIN-CP-OP-504".

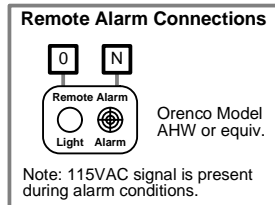
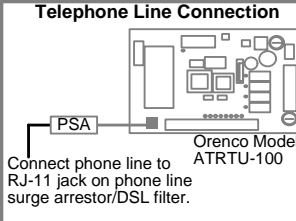

Power Wiring Options

Two Circuits

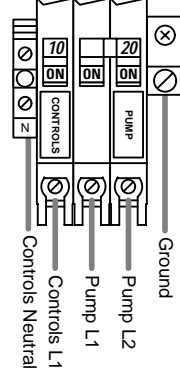

One Circuit

