

# Control Panel Wiring Diagram

## Model MVP-S2 R0 SA

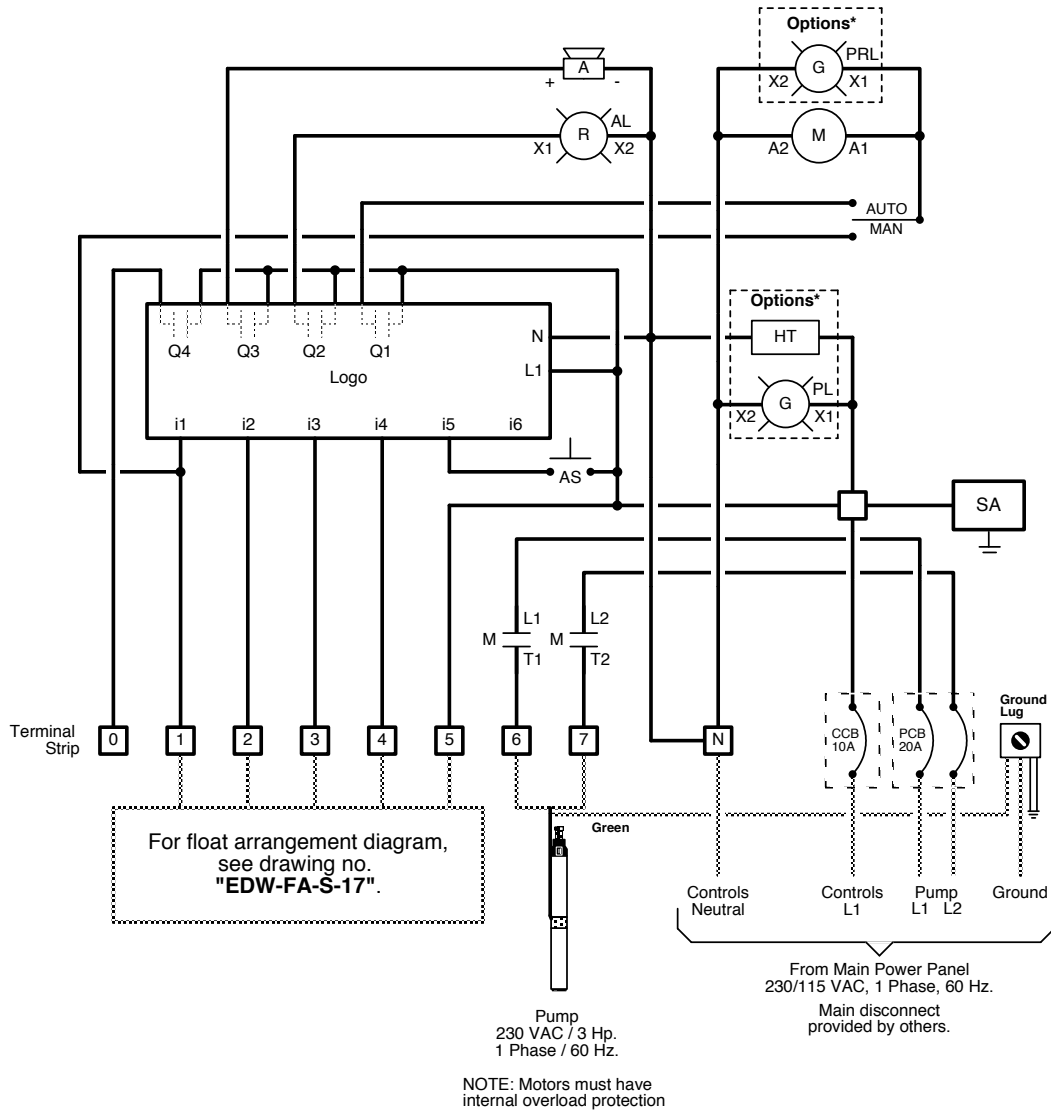

For float arrangement diagram, see drawing no. "EDW-FA-S-17".

### Key

- = Factory Wire
- = Field Wire
- - - = Alternate Field Wire
- A = Audio Alarm, 115 VAC
- AL = Alarm Light
- AS = Audio Silence Switch
- CCB = Controls Circuit Breaker
- Logo = Logic Module
- M = Motor Contactor
- PCB = Pump Circuit Breaker
- SA = Surge Arrester
- TL = Terminal Link

- \*Options**
- HT = Heater
  - PL = Power Light
  - PRL = Pump Run Light

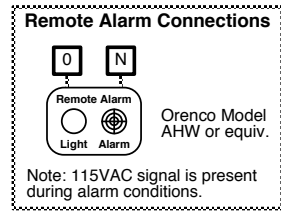

For MVP-S RO operation description, see drawing no. "EIN-CP-OP-183".

