

Control Panel Wiring Diagram

Model MVP-S2 PT R0



Oreco Systems
Incorporated

814 AIRWAY AVENUE

SUTHERLIN, OREGON

97479-9012

TELEPHONE:

(541) 459-4449

FACSIMILE:

(541) 459-2884

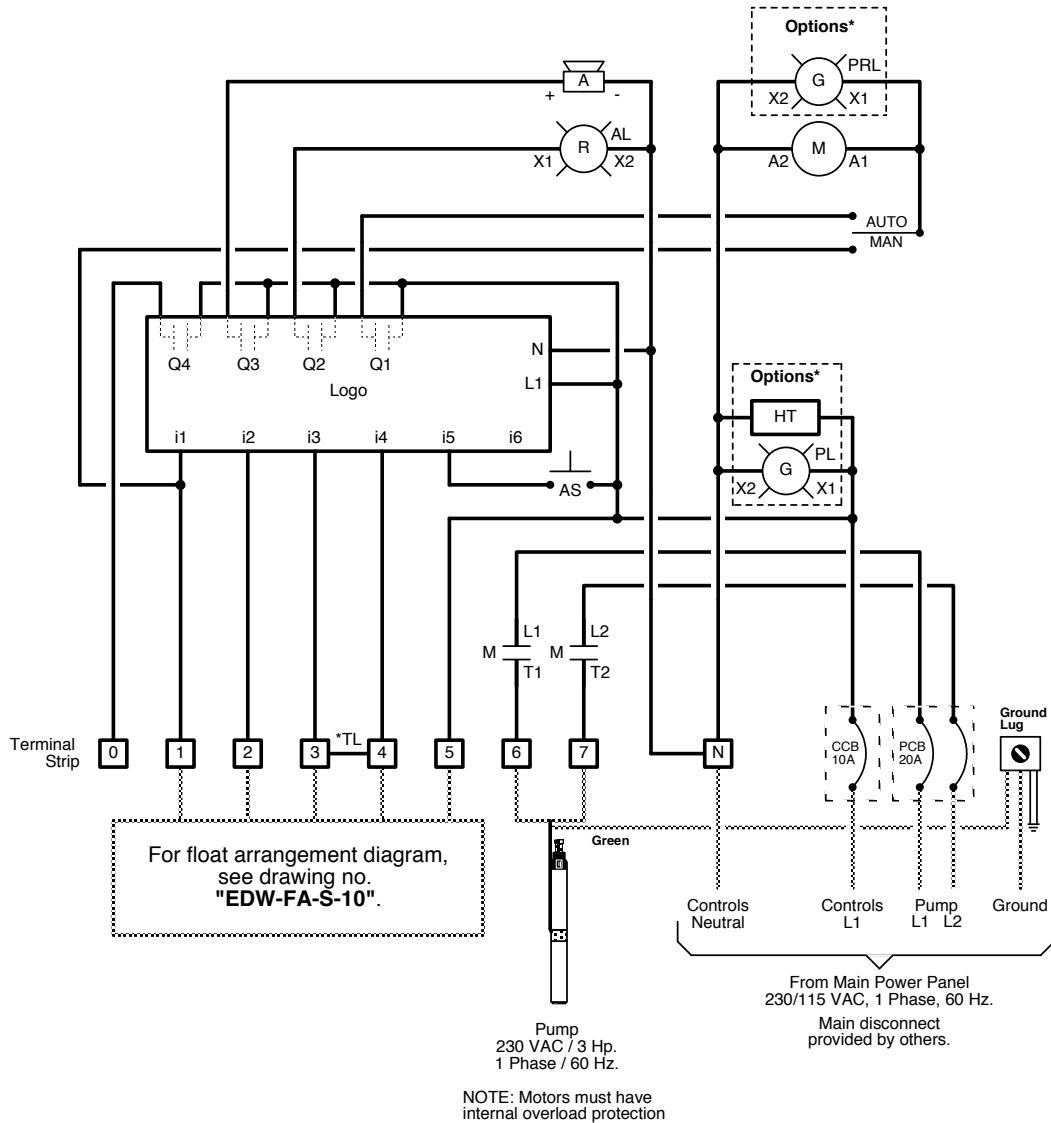

For float arrangement diagram, see drawing no. "EDW-FA-S-10".

NOTE: Motors must have internal overload protection

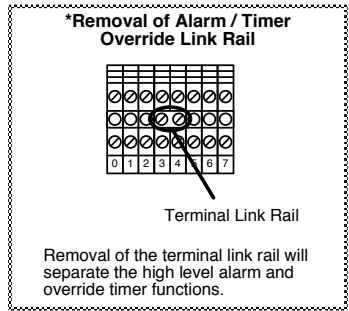

- ### Key
- = Factory Wire
 - = Field Wire
 - · - = Alternate Field Wire
 - A = Audio Alarm, 115 VAC
 - AL = Alarm Light
 - AS = Audio Silence Switch
 - CCB = Controls Circuit Breaker
 - Logo = Logic Module
 - M = Motor Contactor
 - PCB = Pump Circuit Breaker
 - TL = Terminal Link
- ### *Options
- HT = Heater
 - PL = Power Light
 - PRL = Pump Run Light

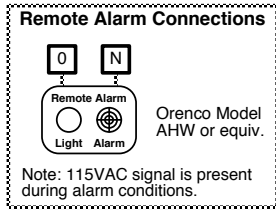

For MVP-S operation description, see drawing no. "EIN-CP-OP-5".

