

# Control Panel Wiring Diagram

## Model MVP-S1 RO CS SA

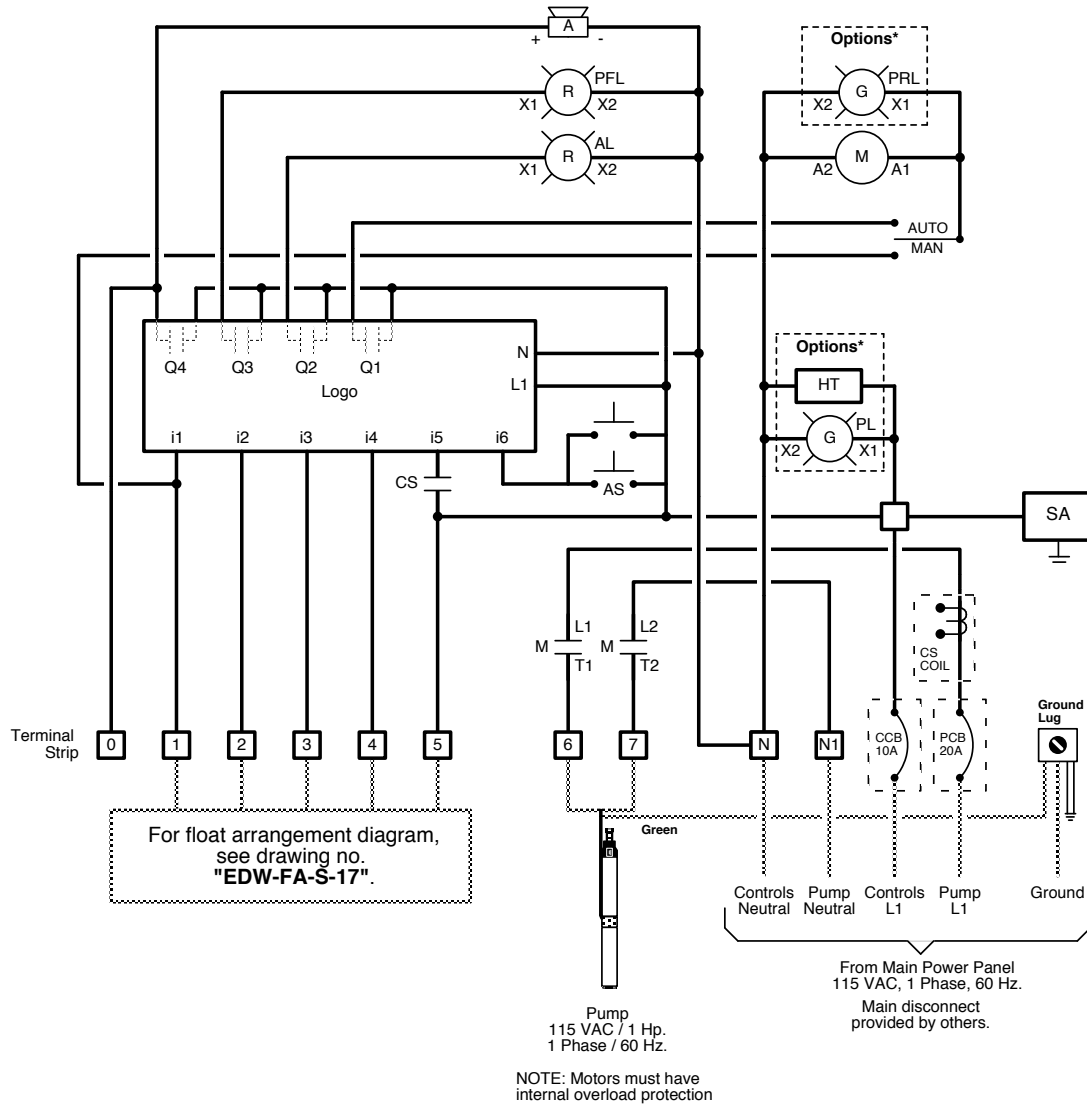

For float arrangement diagram, see drawing no. "EDW-FA-S-17".

NOTE: Motors must have internal overload protection

### Key

- = Factory Wire
  - ⋯ = Field Wire
  - - - = Alternate Field Wire
  - A = Audio Alarm, 115 VAC
  - AL = Alarm Light
  - AS = Audio Silence Switch
  - CCB = Controls Circuit Breaker
  - CS = Current Sensor
  - Logo = Logic Module
  - M = Motor Contactor
  - PCB = Pump Circuit Breaker
  - PFL = Pump Fail Light
  - SA = Surge Arrester
  - TL = Terminal Link
- \*Options**
- HT = Heater
  - PL = Power Light
  - PRL = Pump Run Light

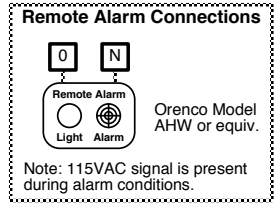

For MVP-S RO CS operation description, see drawing no. "EIN-CP-OP-1123".

