

# Control Panel Wiring Diagram

## Model MVP-DAX2 PTRO CS



814 AIRWAY AVENUE  
SUTHERLIN, OREGON  
97479

TOLL FREE:  
(800) 348-9843

TELEPHONE:  
(541) 459-4449

FACSIMILE:  
(541) 459-2884

WEB SITE:  
www.oreco.com

From Main Power Panel  
230/115 VAC, 1 Phase, 60 Hz.  
Main disconnect  
provided by others.

— = Factory Wire  
— = Field Wire

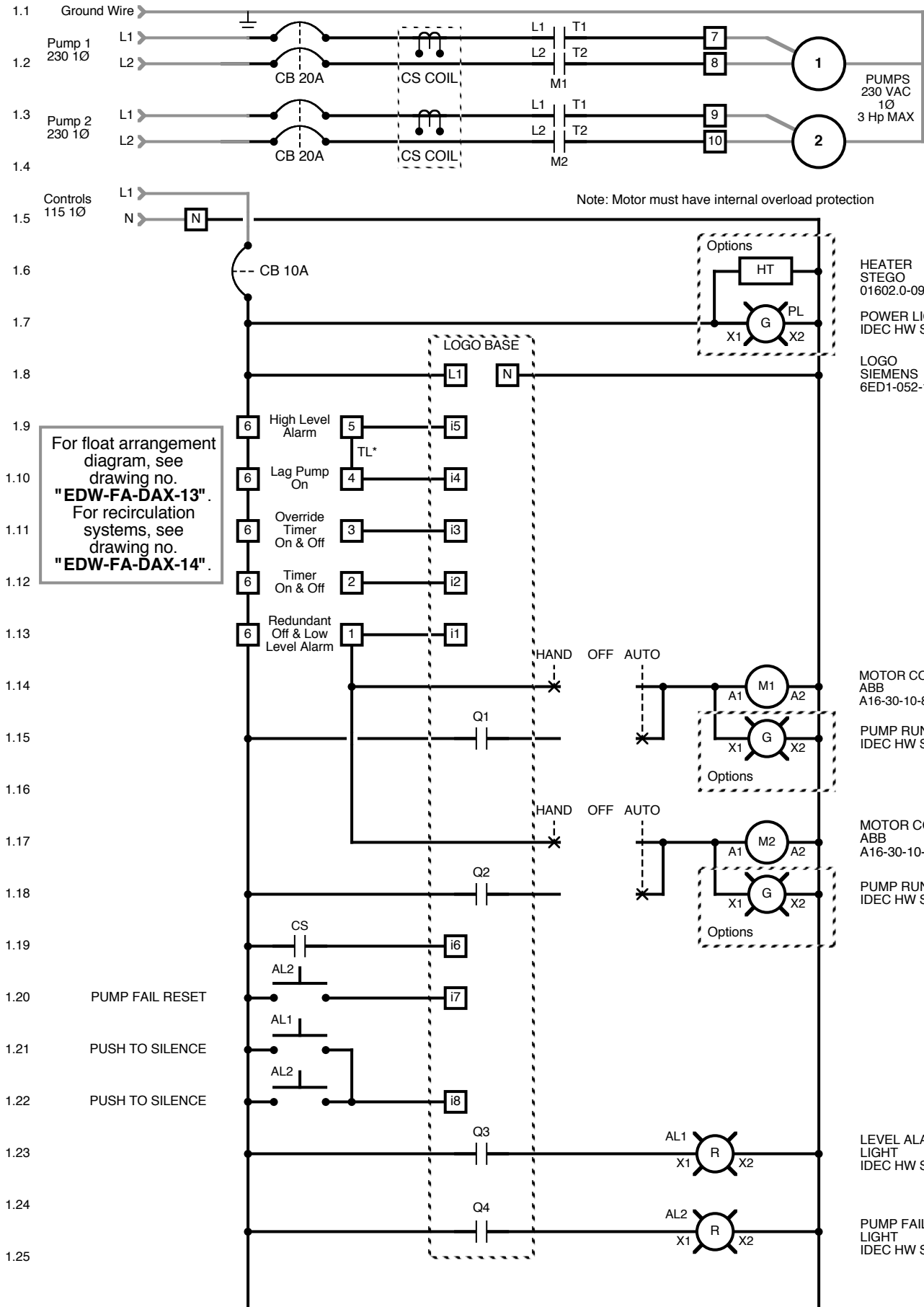

Note: Motor must have internal overload protection

For float arrangement diagram, see drawing no. "EDW-FA-DAX-13".  
For recirculation systems, see drawing no. "EDW-FA-DAX-14".

HEATER  
STEGO  
01602.0-09

POWER LIGHT  
IDEC HW SERIES

LOGO  
SIEMENS  
6ED1-052-1FB00-0BA6

MOTOR CONTACTOR  
ABB  
A16-30-10-84

PUMP RUN LIGHT  
IDEC HW SERIES

MOTOR CONTACTOR  
ABB  
A16-30-10-84

PUMP RUN LIGHT  
IDEC HW SERIES

LEVEL ALARM  
LIGHT  
IDEC HW SERIES

PUMP FAIL  
LIGHT  
IDEC HW SERIES

2.1  
2.2  
2.3  
2.4  
2.5  
2.6  
2.7  
2.8  
2.9  
2.10  
2.11  
2.12  
2.13  
2.14  
2.15  
2.16  
2.17  
2.18  
2.19  
2.20  
2.21  
2.22  
2.23  
2.24  
2.25  
2.26  
2.27

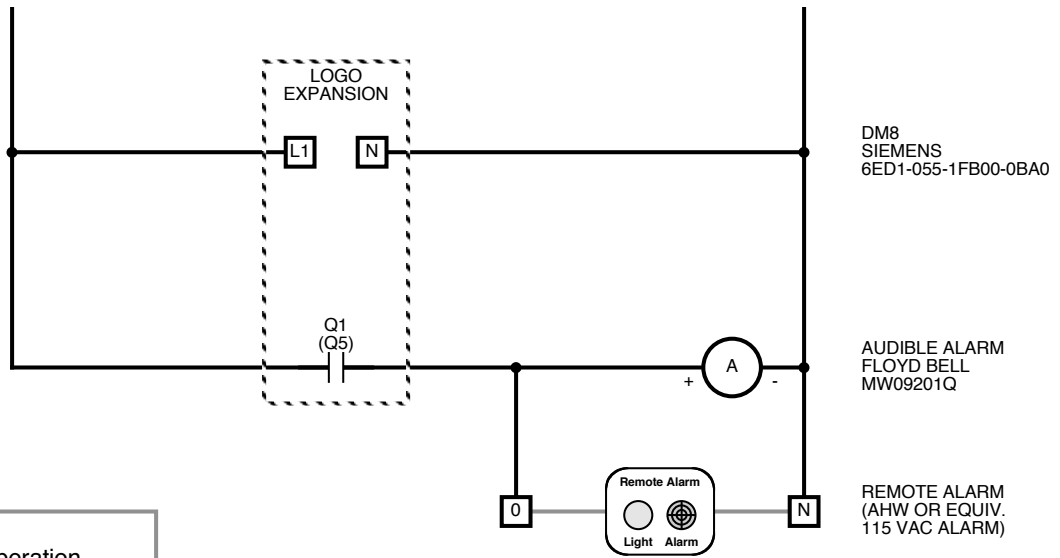

For MVP-DAX operation description, see drawing no. "EIN-CP-OP-54".

**\* Removal of Alarm / Lag Pump On Link Rail**

0	1	2	3	4	5	6	

Removal of the terminal link rail will separate the high level alarm and lag pump on functions.

Terminal Link Rail

**Power Wiring Options**

Three Circuits

Factory default.  
Wire as shown.

Two Circuits

Use one wire nut to connect the first pole of each pump circuit breaker together with the incoming L1 power line. Use another wire nut to connect the second pole of each pump circuit breaker together with the incoming L2 power line.

One Circuit

Use one wire nut to connect the first pole of each pump circuit breaker together with the controls breaker and with the incoming L1 power line. Use another wire nut to connect the second pole of each pump circuit breaker with the incoming L2 power line.