

# Control Panel Wiring Diagram

## Model MVP-S1 DM CS



814 AIRWAY AVENUE  
SUTHERLIN, OREGON  
97479-9012

TELEPHONE:  
(800) 348-9843  
(541) 459-4449

WEBSITE:  
www.orenco.com

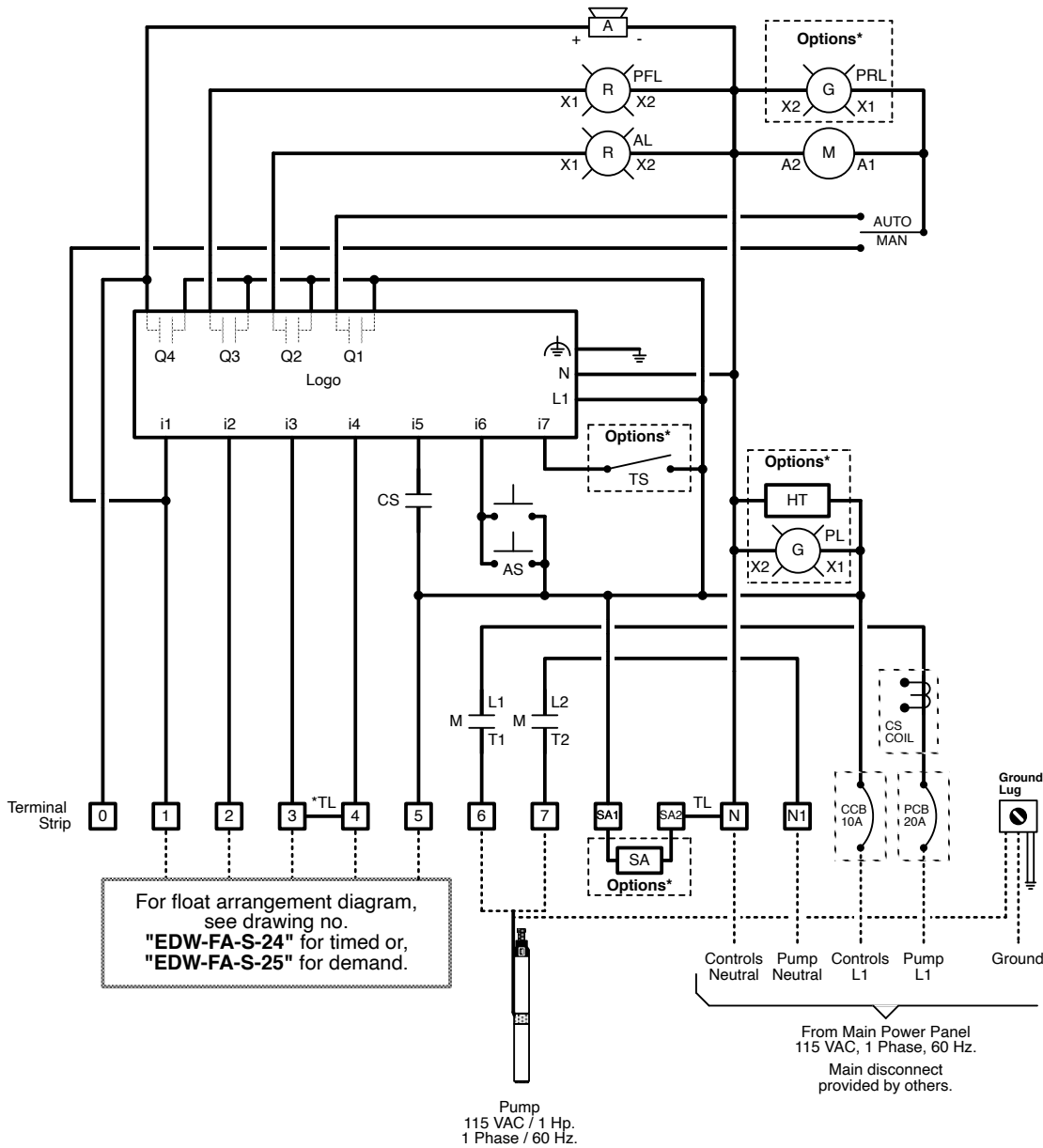

For float arrangement diagram, see drawing no. "EDW-FA-S-24" for timed or, "EDW-FA-S-25" for demand.

NOTE: Motors must have internal overload protection

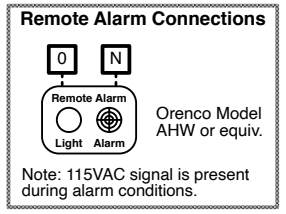
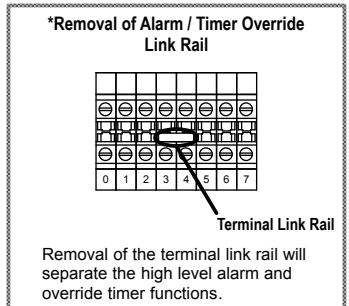

- ### Key
- = Factory Wire
  - = Field Wire
  - - - = Alternate Field Wire
  - A = Audio Alarm, 115 VAC
  - AL = Alarm Light
  - AS = Audio Silence Switch
  - CCB = Controls Circuit Breaker
  - CS = Current Sensor
  - Logo = Logic Module
  - M = Motor Contactor
  - PCB = Pump Circuit Breaker
  - PFL = Pump Fail Light
  - TL = Terminal Link
- ### \*Options
- HT = Heater
  - PL = Power Light
  - PRL = Pump Run Light
  - SA = Surge Arrestor
  - TS = Test Switch

For MVP-S DM CS operation description, see drawing no. "EIN-CP-OP-2048".

