

Panel Wiring Diagram Model MVP-DAX1



Oreco Systems[®]
Incorporated

814 AIRWAY AVENUE

SUTHERLIN, OREGON

97479-9012

TELEPHONE:

(541) 459-4449

FACSIMILE:

(541) 459-2884

Key

- = Factory Wire
 - - - = Field Wire
 - A = Alternate Field Wire
 - AL = Alarm Light, 115 VAC
 - AS = Audio Silence Switch
 - CCB = Controls Circuit Breaker
 - Logo = Logic Module
 - M = Motor Contactor
 - PCB = Pump Circuit Breaker
 - TL = Terminal Link
- *Options**
- HT = Heater
 - PL = Power Light
 - PRL = Pump Run Light

Removal of Alarm / Lag Pump On Link Rail

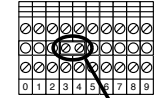

Terminal Link Rail

Removal of the terminal link rail will separate the high level alarm and lag pump on functions.

Remote Alarm Connections

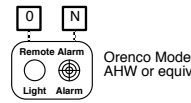

Note: 115VAC signal is present during alarm conditions.

For MVP-DAX operation description, see drawing no. "EIN-CP-OP-150".

Power Wiring Options

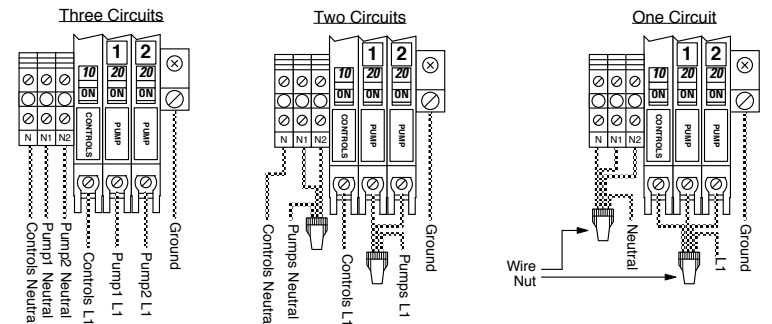

Factory default. Wire as shown.

Use one wire nut to connect the pole of each pump circuit breaker together with the incoming L1 power line. Use another wire nut to connect the neutral block of each pump with the incoming neutral line.

Use one wire nut to connect the pole of each pump circuit breaker together with the controls breaker and with the incoming L1 power line. Use another wire nut to connect the neutral block of each pump with the controls neutral block and with the incoming neutral line.

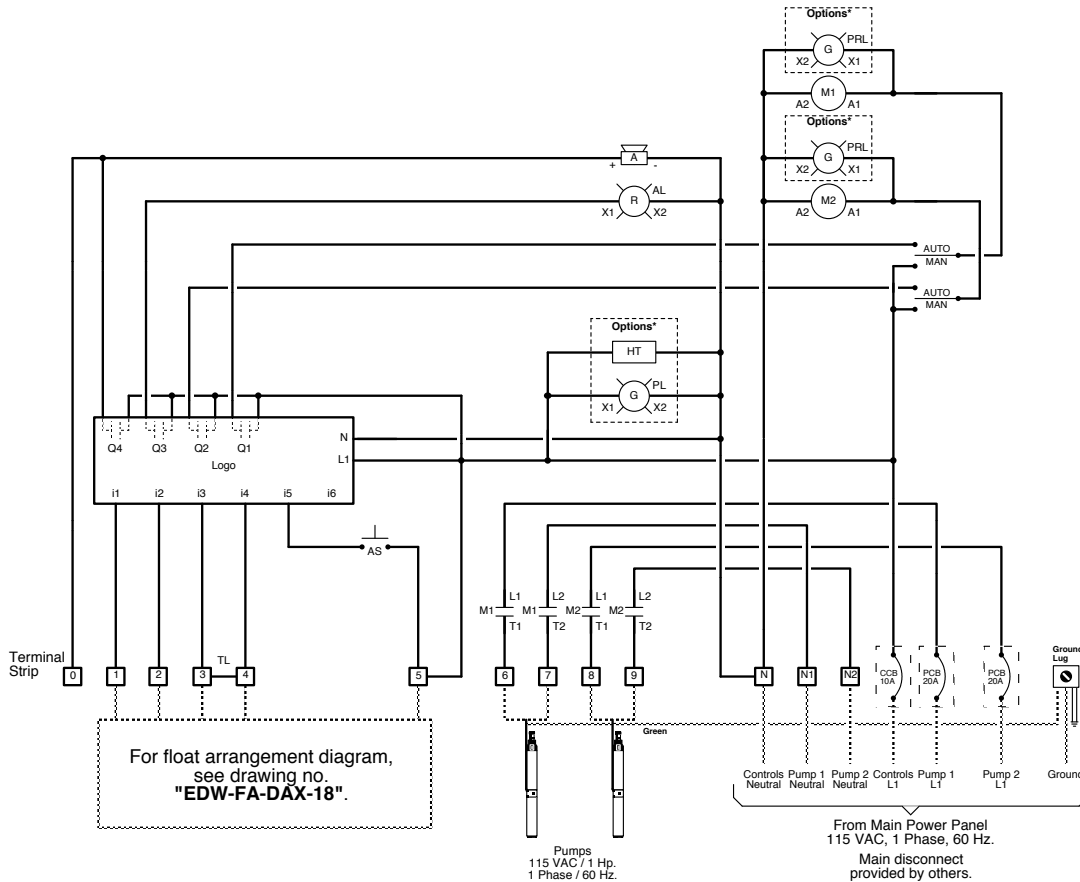

For float arrangement diagram, see drawing no. "EDW-FA-DAX-18".

NOTE: Motors must have internal overload protection