



HYDROCHAIN™ PRIME SEPARATOR

HYDRODYNAMIC TECHNOLOGY FOR ADVANCED STORMWATER MANAGEMENT

The physical technology of the HydroChain Prime Separator removes sediment, solids and heavy metals from stormwater runoff. Most contamination in stormwater is carried by fine particles. Unlike treatment systems that reduce only sand fractions, the separator reduces both silt and sand fractions.

The HDPE unit's inner cylinder separates the water to be treated from floatable materials such as plastic bottles, cans, oil and pollen. The separator is designed to prevent resuspension of sediment.

PROTECTING THE ENVIRONMENT

Stormwater runoff is a significant cause of water pollution. Engineered to meet the most stringent North American and global standards, this separator removes contaminants and produces water clean enough to re-enter surface water, waterways and groundwater infiltration systems. The following certifications and approvals are in process:

- NJ Corporation for Advanced Technology (NJCAT)
- NJ Department of Environmental Protection (NJDEP)
- WA Department of Ecology (WADOE)



HOW THE HYDRODYNAMIC PRIME SEPARATOR WORKS

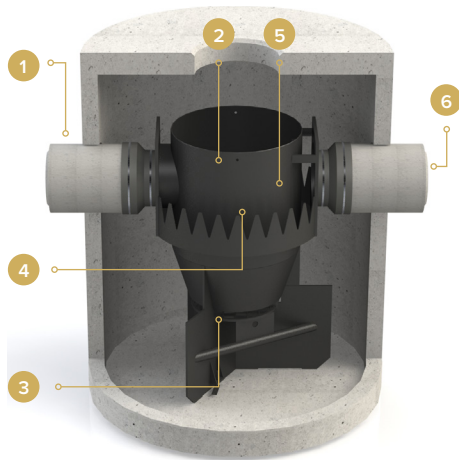

1. Stormwater flows through the inlet pipe into the center of the separator and a deflector plate creates a radial flow pattern.
2. Solids sink to the bottom of the manhole or tank and floatable matter remains on the surface of the water.
3. Solids collect in the manhole or tank bottom, which is separated hydraulically from the treatment funnel by flow breakers (panels) and a grate. Suspended and settled solids are periodically cleaned out.
4. Cleaned water flows evenly upward, along the outer walls of the prime separator.
5. Cleaned water flows over a serrated weir into a channel.
6. The cleaned water flows out of the separator through the outlet pipe.

NOTE: This shows the Prime Separator in a concrete manhole. It is also available in a fiberglass manhole.

Maximum treatment levels

up to 7.0 cubic feet /
200 liters per second

Sediment storage capacities

up to 6.5 cubic yards /
5.0 cubic meters

Oil/debris storage capacities

up to 830 gallons /
3,140 liters

Installed in manholes, tanks or vaults

that are designed to withstand H-25/HS-25 axle loads

FLEXIBLE DESIGN FOR STORMWATER SYSTEMS OF ANY SCOPE

The HydroChain Prime Separator can be used as a single unit or in a series as part of any stormwater management system. It can be installed in a fiberglass or concrete manhole, tank or vault. The Prime Separator can also be used as a component of the HydroChain Complete Treatment System, which also includes HydroChain Filter Cartridges and a HydroChain FRP Tank.

BACKED BY DECADES OF SUCCESSFUL INSTALLATIONS

- 20+ years of stormwater treatment technology
- Site-specific product design by in-house engineers
- Stringent quality-control of manufacturing
- Comprehensive installation instructions

REMOVAL PERFORMANCE

Material	Removal %
Trash and debris	> 90%
Total petroleum hydrocarbons	> 65%
Total suspended solids (TSS)	> 50%
Total heavy metals	> 50%



Contact watersales@shawcor.com for more information on specific material removal.

FOR NEW AND RETROFIT STORMWATER SYSTEMS

- Industrial and commercial sites
- State, provincial and municipal transportation facilities
- Housing developments
- Government facilities
- Highway lane expansion
- Parking ramps and lots
- Schools and athletic facilities
- Health care facilities
- Airports
- Retail fuel and truck stops
- Grocery stores and convenience stores

INSTALLATION AND PERFORMANCE DATA

MODEL Number in model name = standard manhole diameter in feet	Treatment Flow Rate (NJCAT/OK-110) Cu. ft. per second / liters per second	Max. Flow Rate Cu. ft. per second / liters per second
HCPS-3	0.57 / 16	3.61 / 102
HCPS-4	1.02 / 29	7.08 / 200
HCPS-5	1.59 / 45	14.45 / 409
HCPS-6	2.29 / 65	20.81 / 589
HCPS-8	4.07 / 115	28.33 / 802
HCPS-10	6.36 / 180	37.00 / 1048

Maximum flow rates are achieved using custom large-diameter units. Custom units can be ordered for designs up to 48"-diameter inlets/outlets. Manhole diameters and depths may need to be sized up to accommodate large-diameter custom units.

Contact watersales@shawcor.com for more information on specific models and custom units.

Shawcor Ltd. is a leading global company specializing in products, services and solutions for the water, energy, infrastructure and transportation markets. We continually pursue sustainable solutions that protect the environment, conserve resources and extend asset life. Headquartered in Toronto, Canada, Shawcor operates in more than 20 countries and employs approximately 5,000 people.