

# HydroChain™

## Triton Chamber Installation Manual

For Stormwater Management Systems

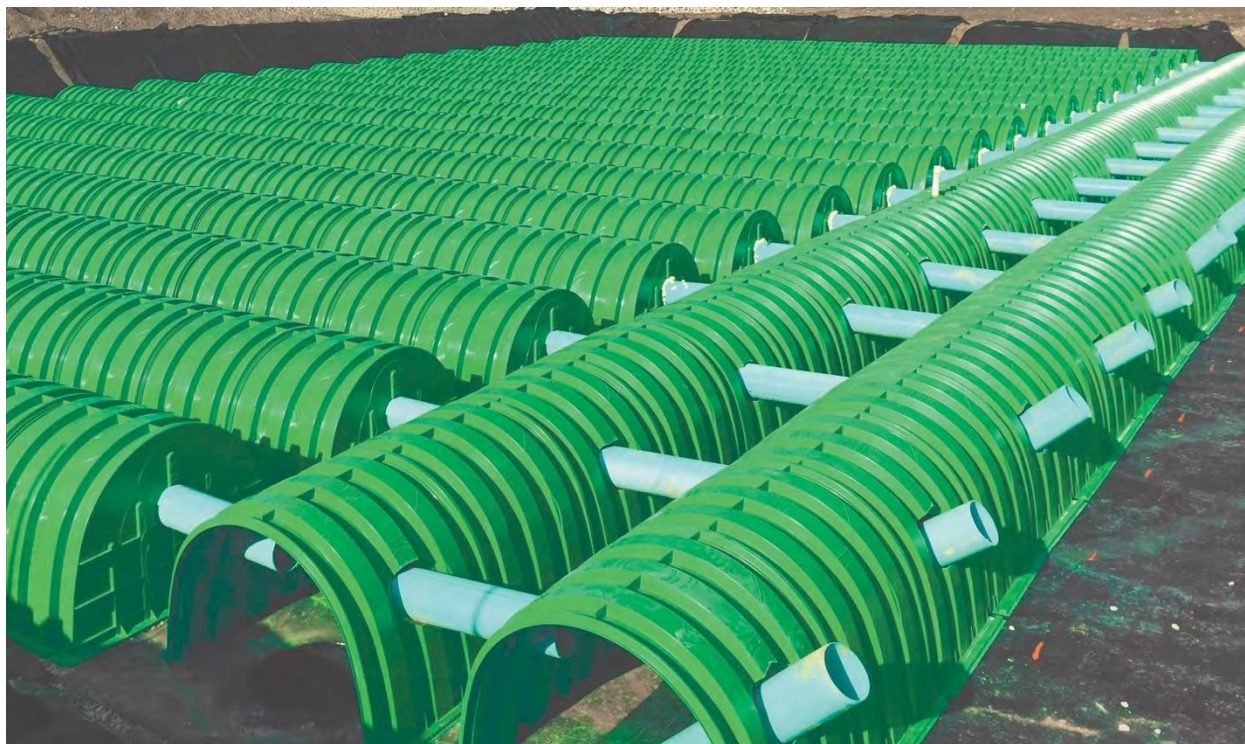

# HydroChain Triton Chamber Installation Manual

This installation guide provides the requirements for proper installation of the HydroChain Triton Chamber system. Failure to follow these instructions may result in damage to chambers during installation. Replacement of damaged chambers during or after backfilling is costly and very time consuming. It is recommended that all installers be familiar with this manual, and that the contractor inspects the chambers for distortion, damage and joint integrity as work progresses. For technical and engineering support, contact us at [stormwater.eng@shawcor.com](mailto:stormwater.eng@shawcor.com).

## TABLE OF CONTENTS

Required Materials and Equipment List .....	2
Requirements for System Installation .....	2
Excavating and Preparing the Site .....	3
Assembling Inlet Pipes .....	4
Installing the Chambers .....	4
Joining the Chambers .....	5
Attaching the End Caps .....	5
Placing Stone with an Excavator .....	6
Placing Stone with a Telescoping Conveyor Boom .....	6
Backfilling the System .....	7
Acceptable Manhole Connection .....	8
Acceptable Geotextiles .....	8
Acceptable Fill Materials .....	9
Assembling the Main Header Row .....	10
Construction Guide .....	13
Backfill of Chambers - Embedment Stone .....	14
Proper Stone Usage .....	16
Complete Stormwater Systems .....	17

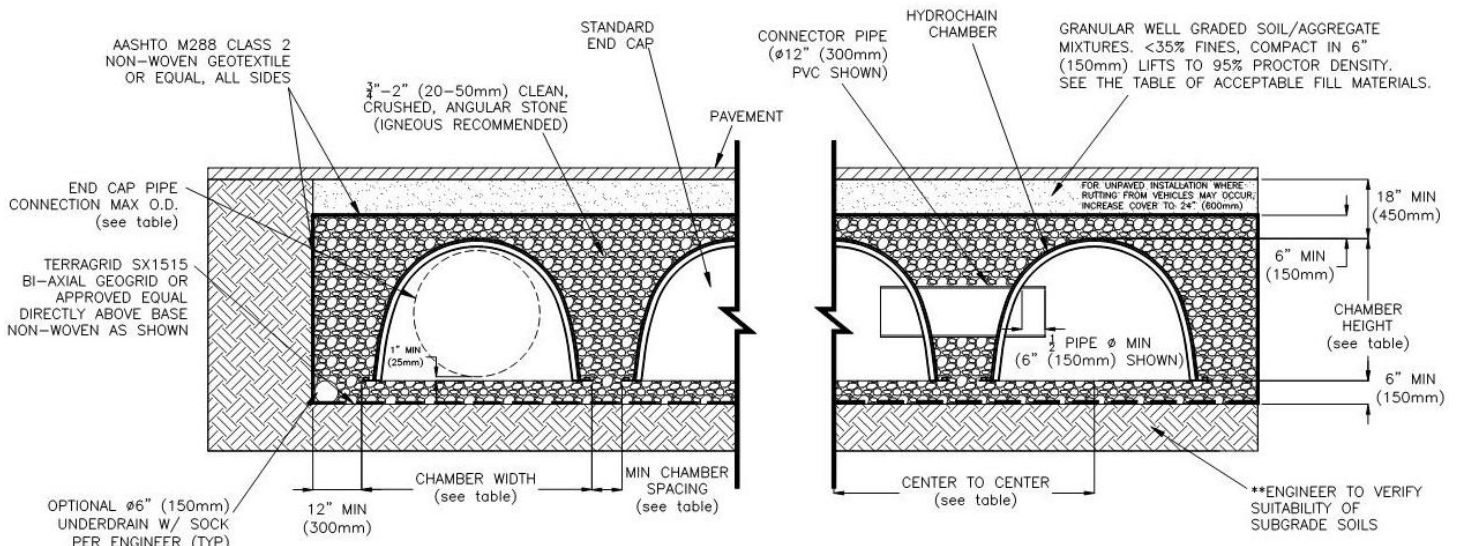

## > Before You Begin

### REQUIRED MATERIALS AND EQUIPMENT LIST

- Acceptable 0.75" – 2" (20mm – 50mm) clean, crushed, angular stone per, Tables 2 & 3 on page 9
- Acceptable fill materials per Table 3 on page 9
- Filter fabric, per Table 1 on page 8
- HydroChain end caps and chambers
- Reciprocating saw with a tapered bi-metal blade, router, jig saw or an air saw (to custom cut end cap, side and top holes). \*Portable air compressor and power source if using an air saw. A proper diameter hole saw works best.
- PVC distribution pipe, per engineer's plan for connecting the HydroChain chamber system together
- Self-Expanding closed cell foams (e.g., Great Stuff™ Pond and Stone insulating foam) to seal all gaps
- OSHA compliance
- Stone bucket
- All equipment must not exceed the ground pressure limits listed in Table 4 on page 13
- Transit or laser
- Vibratory roller with maximum gross vehicle weight of 12,000 lbs. (5443 kg) and a maximum dynamic force of 20,000 lbs. (9072 kg). Also, a walk-behind plate compactor whose compaction force does not exceed 2,500 lbs (10kN).
- Installer(s) should wear proper clothing, gloves, eye protection and a dust mask when cutting.
- Review directions on all products to ensure proper installation
- 60" (1524mm) forks to unload pallets and rope to pull pallets to back of van.
- **Fork pallet only. Do not lift stack by placing forks under product**
- Remove all packaging, i.e., bands, stretch wrap, labels, and protective film, from product before installing them
- A minimum of a 3" (76mm) wide x 10' (3m) Web Sling with a choker load rating of 3,760 pounds (1705 kg) or more to lower product into trench

## > Requirements for System Installation

1. Before installation, installing contractors are to read and understand the HydroChain Chamber Installation Manual in effect at time of installation. Compliance with these instructions are necessary for proper installation, maintenance and use of our chambers.  
  
All illustrations and photographs are examples of typical situations. Actual designs may vary. Be sure to follow the engineer's drawings.
2. We offer installation consultations to installing contractors. Contact us at [stormwater.eng@shawcor.com](mailto:stormwater.eng@shawcor.com) at least 10 days prior to system installation to arrange a pre-installation consultation. Our representatives can answer questions, address comments and provide information about the HydroChain chamber system's installation requirements. Contact us at [stormwater.eng@shawcor.com](mailto:stormwater.eng@shawcor.com) to obtain the current version of the HydroChain Chamber Installation Manual.
3. **Contact local underground utility companies or locating agency at least 3 days prior to construction.**
4. All HydroChain chamber system designs must be certified by a registered professional engineer.
5. Our requirements for systems with a pavement design (asphalt, concrete pavers, etc.): Minimum cover is 18" (457mm) not including pavement; maximum cover is 600" (15240mm) including pavement design. For installations that do not include pavement, where rutting from vehicles may occur, minimum required cover is 24" (610mm), maximum cover is 600" (15240mm).
6. The contractor must report any discrepancies with the system subgrade soil's bearing capacity to the design engineer.
7. Check chambers for shipping damage prior to installation. Units that have been damaged must not be installed. Contact us at [stormwater.eng@shawcor.com](mailto:stormwater.eng@shawcor.com) immediately upon discovery of any damage.
8. Filter fabric must be used as indicated in the engineer's drawings.
9. To maintain row separation distances and prevent chamber displacement, place stone between chamber rows and around perimeter as required by the current version of our installation instructions.
10. Backfilling of the chamber system must be in accordance with the current version of our installation instructions.
11. The contractor must refer to our installation instructions for Tables of Acceptable Vehicle Loads at various depths of cover. The contractor is responsible for preventing vehicles that exceed our requirements from traveling across or parking over the stormwater system. Temporary fencing, warning tape and appropriately located signs are commonly used to prevent unauthorized vehicles from entering sensitive construction areas.
12. The contractor must apply erosion and sediment control measures to protect the stormwater system during all phases of site construction, per local codes and design engineer's specifications.
13. Remove all packaging, i.e., bands, stretch wrap, labels, and protective film, from product before installing them.

### > Requirements for System Installation

- HydroChain chamber systems must be installed in accordance with our minimum requirements. Failure to do so will void the limited warranty.
- The HydroChain chamber product warranty is limited. Contact us at [stormwater.eng@shawcor.com](mailto:stormwater.eng@shawcor.com) to obtain a copy of our limited warranty.
- For installation instructions for any additional structures or fittings not covered in these instructions, contact us at [stormwater.eng@shawcor.com](mailto:stormwater.eng@shawcor.com)
- Contact us at [stormwater.eng@shawcor.com](mailto:stormwater.eng@shawcor.com) to supply us with the vehicle specifications that will be used during the installation of the system 10 business days prior to start of installation for approval.
- When light pole bases are located within the footprint of the system, prior to installation of the system, the electrical contractor must be consulted to ensure sufficient room has been provided for light pole base excavation.

### > Requirements for Excavating and Preparing the Site



- Excavate and level the designated area. Be sure to excavate at least one extra foot around the chamber perimeter to allow for proper fit and adequate compaction. (Bed dimensions are specified on engineer's plan.)
- Excavation must be free of standing water. Dewatering measures must be taken if required. Positive drainage of the excavation must be maintained.
- Prepare the chamber bed's subgrade soil as outlined in the engineer's drawings.
- Line trench walls with any of the acceptable AASHTO M288 class 2 Non-Woven geotextiles listed in table 1 on page 8. Overlap adjacent filter fabric by at least 2' (610mm).
- Perforated pipe outlet underdrains may be designed within the one foot stone perimeter. Install perforated pipe outlet underdrains as required by the engineer's drawings.
- Place acceptable 0.75" - 2" (20mm - 50mm) clean, crushed, angular stone foundation material over the entire bottom surface of the bed (see Tables 2 & 3 on page 9 for stone requirements). Refer to the engineer's drawings for subgrade soil preparation and required stone foundation thickness.
- Compact the stone using a vibratory roller with its full dynamic force applied to achieve a flat surface.



Use a plate compactor to achieve a flat surface. Compaction of the embedment stone is necessary if the angular stone used is of nominal graded size less than 1.5" (40 mm).

## > Requirements for Assembling Inlet Pipes

**NOTE:** Depending on the system's design, it may be advantageous to lay out the inlet and outlet pipe systems prior to forming the bed of chambers.

1. Temporarily lay out the main header system according to the engineer's drawings.
2. Stone foundation scour control measures such as splash pads, riprap, or geotextiles may be required by the design engineer. Locate and install scour control measures, per engineer's drawings, if required.
3. Set first chamber of each row aligned with their inlet pipes, if applicable, or with the Main Header Row.

Per the engineer's drawings, ensure that the minimum\* clear spacing, measured between feet, is maintained between adjacent rows. Separate chambers and inlet fittings, as necessary, to maintain the minimum separation distance between chamber rows.

4. Pre-drill a hole large enough to use a saw listed on page 2 under the "Before you Begin" section. Cut an opening for the inlet piping in the applicable end caps at the specified invert height.

**NOTE:** Inlet pipe openings may be cut anywhere on an end cap along the vertical centerline. To do this, take a short length of pipe and use a marker to draw an outline of the pipe on the end cap at the correct height or use the proper diameter guides on the face of the end cap to cut required hole.

5. Insert the distribution pipes into the end caps.
6. Once chamber spacing requirements are met, the header row system may be permanently assembled.

For more details on installing the HydroChain chamber Main Header Row system go to page 10.

\* A wider spacing may be required, as indicated on the engineer's drawings.

## > Requirements for Installing the Chambers



From the start of the first picture to the last picture it took the two men 8 seconds to install the three chambers they were carrying.

To begin building the chamber bed, orient the chambers so the end labeled with the build direction arrow is pointed in the direction of the build.

Maintain the minimum separation between chamber rows (measurement taken from the foot of chambers).

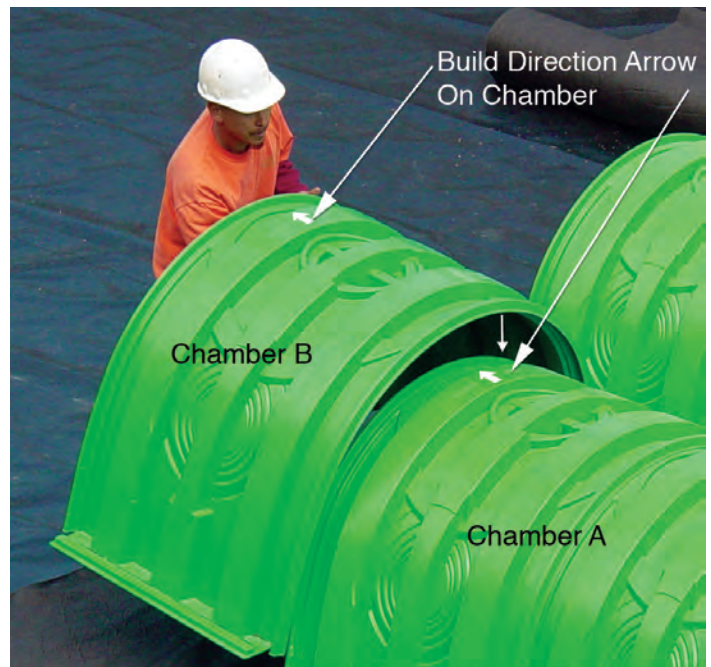

With the Build Direction Arrow nearest you, lower Chamber B over the last rib on Chamber A.

## > Requirements for Joining the Chambers



Improper installation. The flange of the chamber is not supported.



Improper installation. The connecting joint is not tight.

Although not visible to the eye, a chamber's end corrugations are sized differently to allow for an overlapping joint. To ensure proper joint fit, orient all chambers in the bed with their arrows pointing in the direction of the build.

Construct the chamber bed by joining the chambers lengthwise in rows. Attach chambers by overlapping the end corrugation of one chamber onto the end corrugation of the last chamber in the row. **Be sure that chamber placement does not exceed the reach of the construction equipment used to place the stone.**

Make sure that the chamber and end cap flanges are sitting on the base stone. Base stone must provide support under the products. Also, make sure that the connecting joints are seated tightly together. The connecting joints should be tight and no gaps should be present.

**NOTE: Do not overlap more than one corrugation.**

## > Requirements for Attaching the End Caps



**NOTE: End caps are required only at the beginning and the end of each row of chambers. (S29 Shown)**

Slide the S29 end cap over the end of the last Chamber. The end caps sits on the outside of the Chamber rib and not on the inside.

Make sure that the S29 end cap is properly seated onto the chamber and that the flange of the end cap is not overlapping or resting on the side flange of the chamber. The end cap should not sit higher than the first full corrugation.

To install the S22, C10 and M6 end caps, lift the end of the chamber a few inches off the ground. With the curved face of the end cap facing outward, place the end cap up inside the chamber's V rib. These end caps sit on the inside of the chamber rib and not on the outside.

Four self-tapping screws can be used to screw the end cap in place to keep it from shifting during the backfill process. The 4 screws can be equally spaced and drilled through the face of the end cap an 1.5"(38.1mm) from the outer edge. Ensure that all the screws penetrate the end cap and the last chamber V rib.

## > Requirements for Placing Stone Over the Chambers



Clean, crushed, angular stone meeting the specifications in Tables 2 & 3 and Figure 1 on page 9 may be placed over the chambers with an excavator, pushed with a dozer or walked in with a stone conveyer boom. Each method has benefits and limitations. These three processes will be explained separately; however, there are some common requirements for each:

The minimum clear spacing must always be maintained between adjacent HydroChain chamber rows and construction vehicle loads must not exceed the requirements of Table 4 on page 13.

Ensure that the stone is of mixed size consisting of 0.75" to 2" (19mm to 51mm) and meets the requirements listed on page 9 of this manual.

## > Requirements for Placing Stone with an Excavator



Installing embedment stone around chambers.

Placing stone with an excavator is currently the most common method of placing stone over HydroChain chambers. Its biggest limitation is the reach of the excavator arm. For larger beds, it is common practice to work across a bed by joining only a few rows of chambers and placing their angular stone embedment, the filter fabric and soil fill before moving onto the next few rows.

A bed may be built either parallel to or perpendicular to the chamber row's direction with this process. The excavator typically works inside the excavation, leading the way across the bed. It is also possible for the excavator to work at grade over the recently placed chambers following the build across. If this process is used, it is required that the depth of cover between tops of chambers and the excavator's tracks be the minimum required by Table 1 on page 8. **No excavators shall be operated on the bed without at least 3 ft (1m) of cover above chambers.**

1. Anchor chambers by ladling angular stone directly over the centerline of the chambers. Evenly distribute stone to minimize chamber movement while maintaining row separation distances.
2. After chambers are anchored, continue to place the stone, surrounding the chambers and filling the perimeter areas to a minimum of 6" (152mm) over the top of chambers. Stone column height should never differ by more than 12" (305mm) between adjacent chamber rows or between chamber rows and perimeter. **Do not drive equipment over the chambers without minimum cover required by Table 4 on page 13.**
3. Repeat steps 1 & 2 until all the chambers are laid to the dimensions of the engineer's drawing.

## > Requirements for Placing Stone with a Telescoping Conveyor Boom

Telescoping aggregate conveyer trucks are limited only by the range of the boom. Typical trucks have a boom range between 50' (15m) to 130' (40m). Booms can convey up to 360 cu ft (10m<sup>3</sup>) of stone per hour.

1. Anchor chambers by ladling angular stone directly over the centerline of the chambers. Evenly distribute stone to minimize chamber movement while maintaining row separation distances.
2. After chambers are anchored, continue to place the stone, surrounding the chambers and filling the perimeter areas to a minimum of 6" (152mm) over the top of chambers.

Do not drive equipment over the chambers without minimum cover required by Table 4 on page 13. As the stone is being placed over the system, the application of the stone over the products must not be stationary. The conveyer must be moving, left and right, fore and aft, to ensure that the stone is not wearing away the product's material. The stone must also be installed over the system evenly as described in this manual. The maximum height from which stone should be dropped onto the system should not exceed 3 ft (1M).

3. Repeat steps 1 & 2 above until all the chambers are laid to the dimensions of the engineer's approved drawings.



**NOTE:** Where site access is limited it is highly recommended to use a telescopic belt conveyor (telebelt) type of truck shown above.

### > Requirements for Backfilling the System

1. Place the required angular stone over the entire bed area as described in previous sections.
2. Line the trench walls with AASHTO M288 Class 2 non-woven filter fabric. Take the fabric from the perimeter and lay it over the top of the stone. The filter fabric must overlap at least 2'(610mm) where the edges of the fabric meet.
3. The first 12"(305mm) of fill material must meet the requirements of Table 3 on page 9. Backfill over the top of the filter fabric in lifts that do not exceed 6"(152mm). Distribute the fill with a construction vehicle that meets the maximum wheel loads or ground pressure limits specified in Table 4 on page 13.
4. Compact each lift of backfill as specified in the engineer's drawings. We require compacting to a minimum of 95% of the Standard Proctor density. Use a walk-behind or vibratory roller not to exceed a maximum gross vehicle weight of 12,000 lbs (5443kg) and a maximum dynamic force of 20,000 lbs (9072 kg).
5. Continue to backfill over the chamber bed in 6"(152mm) maximum lifts until the specified grade is achieved. Our chamber cover requirements are 18"(457mm) minimum and 600"(15240mm) maximum over the top of the chambers. For pavement sub-base or special fill requirements, see engineer's drawings.

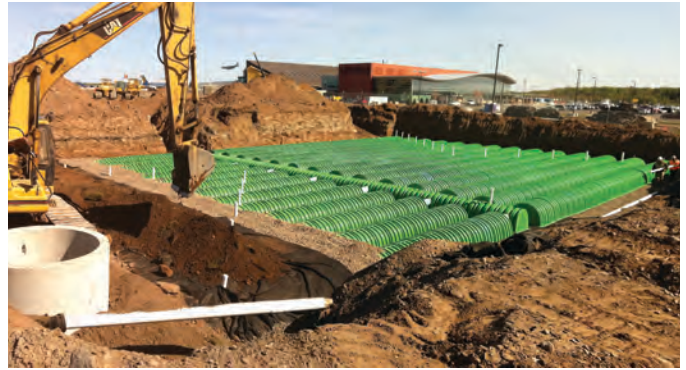

The backfill height differential should never differ by more than 12" (305mm) over adjacent chambers. Minimum cover heights must be met before vehicles are allowed on top of the system. Large rocks and organic matter such as roots, stumps, etc. must not be part of the backfill material. Refer to Table 3 on page 9 for Acceptable Cover Materials or contact the design engineer for approved fill types. Refer to the Backfill of Chamber-Empediment Stone drawing on page 15.





## > Acceptable Manhole Connection

**NOTES:**

1. PIPE/MANHOLE CONNECTIONS TO BE GROUTED.
2. PIPE/CHAMBER CONNECTIONS PER LATEST INSTALLATION INSTRUCTIONS.

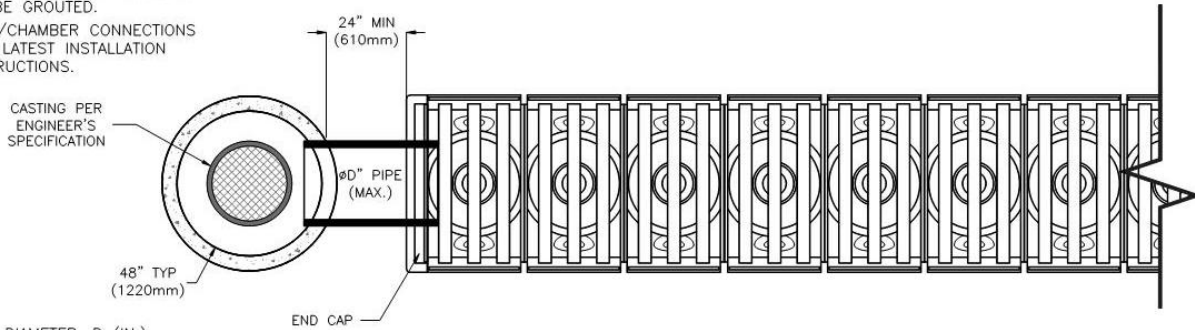

**MAX PIPE DIAMETER, D (IN.):**

- S-29 CHAMBERS = 24" (610mm)
- S-22 CHAMBERS = 24" (610mm)
- C-10 CHAMBERS = 18" (450mm)
- M-6 CHAMBERS = 12" (300mm)

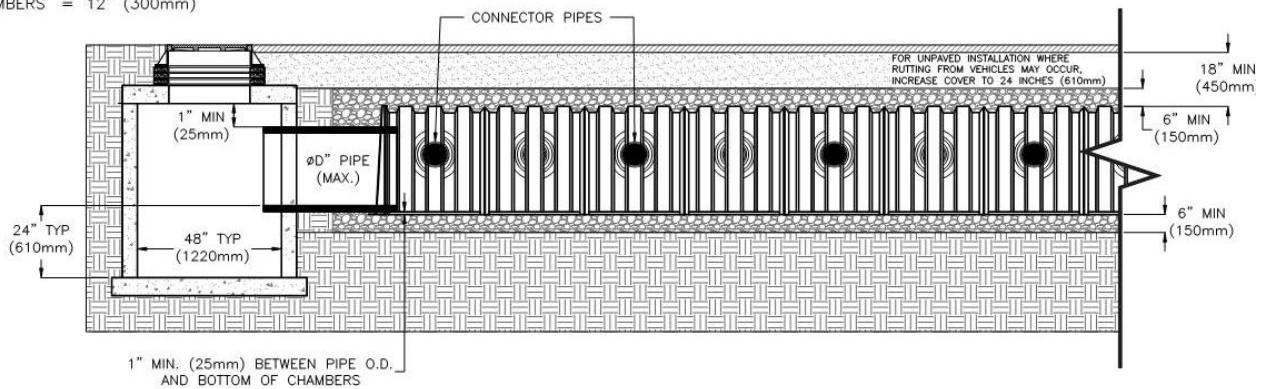

## > Acceptable Geotextiles

**TABLE 1 - Some Suitable Geotextiles**

MANUFACTURER	AASHTO M288 CLASS 2 NON-WOVEN <sup>1</sup>	AASHTO M288 CLASS 1 WOVEN <sup>2</sup>
Amoco Fabrics and Fibers (Part of BP)	ProPex 4506, ProPex 4508, ProPex 4551, ProPex 4552, ProPex 4553	ProPex 2006, ProPex 2016, ProPex 2004
BTL Inc. (Bend Tarp Liners)	Style 801, 8 oz., GN200	PPL-20, PPL-24, PPL-36
Carthage Mills	FX-60HS, FX-80HS	FX-66
TerraFix Geosynthetics Inc.	360R, 400R, 420R	200W, 400W
GSE Lining Technology	NW6, NW8	—
Maccaferri	MacTex MX245, MacTex MX275	—
Mirafi Const. Products	Mirafi 160N, Mirafi 180N	Mirafi 600X, Filterweave 403, Filterweave 404, Geolon HP570, Geolon HP665m /geikib HP770
Pavco-Amanco	NT 3000, NT 4000	TR 4000
SI Geosolution	Geotex 601, Geotex 801	Geotex 315ST
TNS Advanced Tech.	R060, R070, R080, R100	M 403
US Fabrics	US 205NW-C	US 315
Hanes Geo	TeraTex N06, TeraTex N08	TeraTex HD

<sup>1</sup> AASHTO M288 Class 2 Non-Woven Geotextile Application: Separation layer between angular stone cover and fill to prevent fines intrusion.

<sup>2</sup> AASHTO M288 Class 1 Woven Geotextile Application: Stabilization layer for angular stone foundation to prevent scouring of the stone base during JetVac maintenance procedure, modest hydraulic flows maintained. Can also be used in place of the Sediment Floors at each inlet row and Main Header Row to prevent scouring of foundation stone.

## > Acceptable Fill Materials

TABLE 2 - Criteria for Acceptable 0.75" – 2" (20mm – 50mm) Clean, Crushed, Angular Stone (igneous recommended)

CLEAN CRUSHED STONE	DESCRIPTION	CRITERIA
Acceptable	Angular	Stones have sharp edges and relatively plane sides with unpolished surfaces
	Subangular	Stones are similar to angular description but have rounded edges
Unacceptable	Subrounded	Stones have nearly plane sides but have well-rounded corners and edges
	Rounded	Stones have smoothly curved sides and no edges

NOTE: See (A) & (B) of Table 3 for additional angular stone requirements.

TABLE 3 - Acceptable Fill Materials

MATERIAL LOCATION	DESCRIPTION	AASHTO M43 DESIGNATION	AASHTO M145 DESIGNATION	COMPACTION/DENSITY REQUIREMENT
D. Fill Material from 18" to grade above chambers	Any soil/rock Materials, native soils or per engineer's plans. Check plans for pavement subgrade requirements.	N/A	N/A	Prepare per engineer's plans. Paved installations may have stringent material and preparation requirements.
C. Fill Material for 6" (155mm) to 18" (457mm) elevation above chambers 24" (610mm) for unpaved installations	Granular well-graded soil/aggregate mixtures, <35% fines. Most pavement sub-base materials can be used in lieu of this layer.	3, 357, 4, 467, 5, 56, 57, 6, 67, 68, 7, 78, 8, 89, 9, 10	A-1 A-2 A-3	Compact in 6" (154mm) lifts to a minimum 95% Standard Proctor density. Roller gross vehicle weight not to exceed 12,000 lbs. (5443 kg) Dynamic force not to exceed 20,000 lbs. (9072 kg).
B. Embedment Stone surrounding and to a 6" (154mm) elevation above Chambers	3/4" – 2" (20-50mm) Clean, crushed, angular stone (igneous recommended)	3, 357, 4, 467, 5, 56, 57	N/A	No compaction required if mixed stone is used.
A. Foundation Stone below Chambers	3/4" – 2" (20-50mm) Clean, crushed, angular stone (igneous recommended)	3, 357, 4, 467, 5, 56, 57	N/A	Plate compact or roll to achieve a 95% Standard Proctor Density.

PLEASE NOTE:

- The listed AASHTO designations are for gradations only. The stone must also be clean, crushed, angular. For example, a specification for #4 stone would state: "clean, crushed, angular no. 4 (AASHTO M43) stone."
- As an alternate to Proctor Testing and field density measurements on open graded stone, our compaction requirements are met for "A" location materials when placed and compacted in 9" (229 mm)(max.) lifts using two full passes with an appropriate compactor.

FIGURE 1 - Fill Material Locations

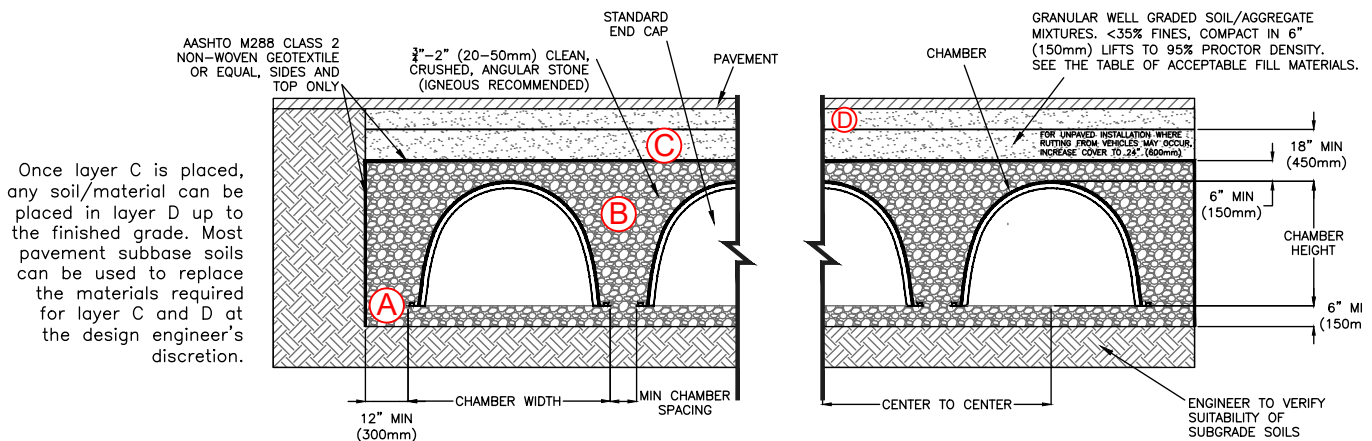

## > Requirements for Assembling the HydroChain Main Header Row System

1. Locate installed catch basin or mechanical filter. (Shown as item 1, figure 2.)
2. Determine length of main inlet pipe from catch basin or mechanical filter to feed the Main Header Row. (Shown as item 2, figure 2.)
3. Temporarily lay out the sediment floor according to the engineer's drawings to determine installation location of the dumpster and/or sump bin assembly. (Shown as item 3, figure 2.)(If required.)
4. Once dumpster and/or sump bin location has been determined, contractor can then excavate and install dumpster and/or sump bin assembly. (Shown as item 4, figure 2.)(If required.)
5. Install the permanent sediment floor according to engineer's drawings. The sediment floor sections should be installed in the build direction indicated by the arrows on the surface of the floor sections. (Shown as item 5, figure 2.)When a dumpster assembly is present, it is recommended to start from the dumpster assembly and build the Main Header Row toward the inlet structure. Otherwise the build direction can start from inlet structure.

6. Install first chamber section and end cap in Main Header Row in the build direction indicated by the arrows on the top surface of each chamber. (Shown as item 6, figure 2.)
7. Install main inlet pipe(s) from catch basin or mechanical filter into the end cap of the first chamber section of the Main Header Row. (Shown as item 7, figure 2.)

**NOTE:** If main inlet pipe does not fit tightly into end cap, then wrap end of distribution pipe with geo-fabric to remove any slack to get a secure fit. Wrap geo-fabric ONLY on the outer wall of the distribution pipe, making sure not to obstruct any end of distribution pipes. You may also use self-expanding closed cell foam (e.g. Great Stuff™ Pond and Stone) to seal around the opening.

**NOTE:** If the end caps and Main Header Row's chambers have not been cut at the factory, then cut end caps and chambers that will receive the distribution pipes BEFORE building into rows. This will assure proper fit and correct cutting locations and will also give adequate room to cut openings before the system is built.

**NOTE:** If any hole is cut 2" (51mm) larger than pipe O.D. then that product (I.E. chamber, end cap) must be replaced.

FIGURE 2

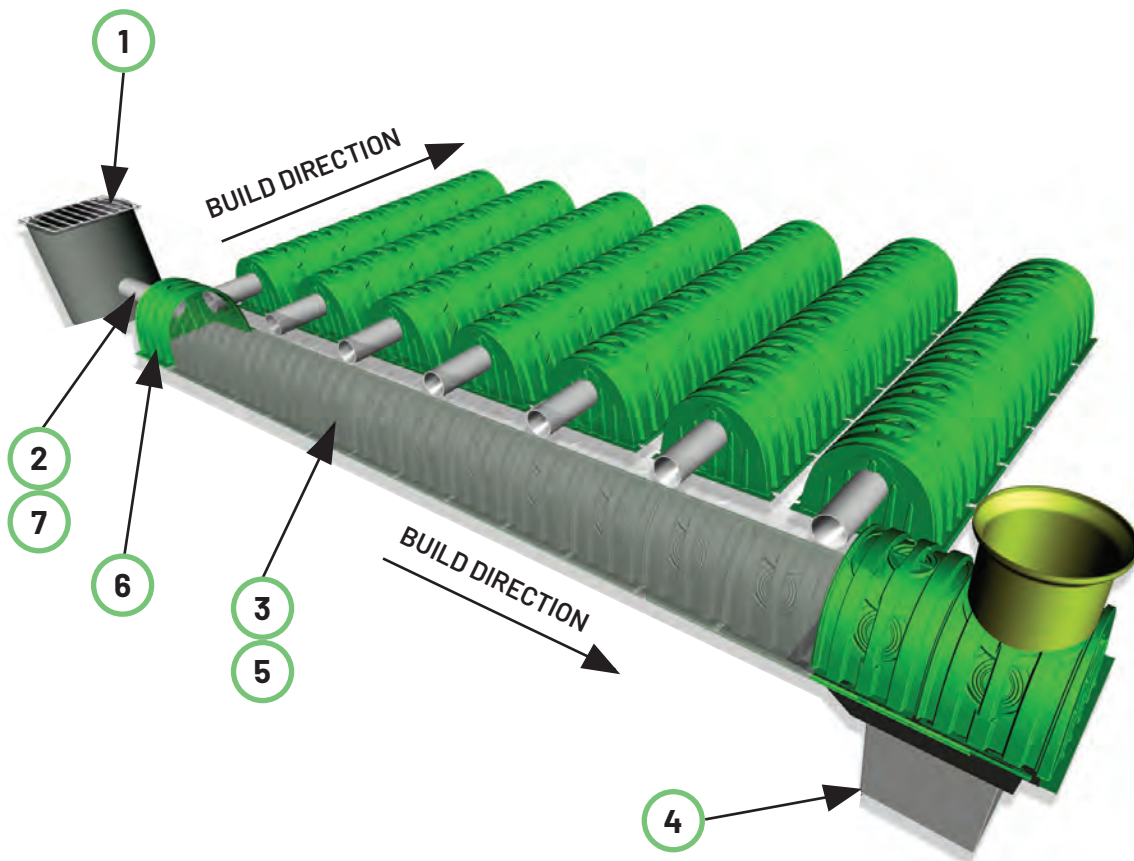

> Requirements for Assembling the HydroChain Main Header Row System (Cont.)

8. Continue with installation of chamber sections in the build direction indicated by the arrows on the top surface of each chamber to construct the Main Header Row. Chamber sections should fit securely on top of the sediment floor. (Shown as item 8, figure 3.)
9. Once the Main Header Row has been installed onto the sediment floor and the dumpster, install the O.D. manhole access drop (allowable sizes shown on standard detail sheet for Inspection/ Direct Top MH connection). Use a jigsaw, reciprocating, or air saw to cut the appropriate diameter opening to accept the manhole access drop. Attach four small galvanized angle brackets equally spaced approximately ONE (1) foot up from the end of the pipe. Use half inch screws on riser pipe to fasten the 4 small galvanized brackets. It is not necessary to screw the angle brackets to the chambers. The purpose of the angle brackets is to support the pipe until the backfill is placed. To help hold pipe in place during backfill, use the recommended spray foam (Great Stuff Pond & Stone) and dual-walled HDPE pipe for access port. Insert the bottom foot of pipe into the top porthole of the chamber and backfill. Attach top of riser pipe to a "Fernco Type" rubber cap, or to a cleanout cover assembly, as specified on the engineering drawings. Place an access casting in a concrete pad above, once all fill is placed, for risers in pavement. (Shown as item 9, figure 3.)
10. Locate and cut out specified side porthole diameters on all chambers of the Main Header Row (pre-drill large enough hole to insert blade for start of cut). (Shown as item 10, figure 3.)
11. Once all side portholes have been cut to the specified diameter, install all distribution pipes. (Shown as item 11, figure 3.)

**NOTE:** If distribution pipes do not fit tightly into side portholes, then wrap end of distribution pipe with geo-fabric to remove any slack and get a secure fit. Wrap geo-fabric ONLY on the

outer wall of the distribution pipe, making sure not to obstruct any end of distribution pipe, or you can also use self-expanding closed cell foam (e.g. Great Stuff™ Pond and Stone) to fill in the gaps.

12. Once all distribution pipes have been properly installed in the side portholes of the Main Header Row, set each chamber of each row aligned with their distribution pipes. Add self-expanding closed cell foam to seal gaps around pipe entering through the chambers and end caps. (Ensure that spacing between rows is per engineer drawings and that minimum spacing requirements are met.) Separate chambers and distribution fittings as necessary to maintain the minimum clear space between chamber rows. Install the end cap onto the first section of each row of chambers in the drain field. With a jigsaw, reciprocating saw, or air saw cut an opening for the distribution pipe in the applicable end caps at the specified invert height to accept the distribution pipe. (See Figure 4.) Slide chamber with the installed end cap over the end of the distribution pipe. (See Figure 5.) Once chamber spacing requirements are met, the rest of the chambers making up the drain field can now be installed. (Shown as item 12, figure 3.) A minimum of 12" (305mm) spacing is required between Main Header Row and distribution row chambers.
13. Install end caps at the end of each chamber row. (Shown as item 13, figure 3.)

**NOTE:** End caps are required only at the beginning and end of each row of chambers

In the event that additional sediment floors, dumpster and/or sump bins are to be installed along with manhole access points refer to engineer's drawings and contact us at [stormwater.eng@shawcor.com](mailto:stormwater.eng@shawcor.com).

FIGURE 3 - Distribution Pipes

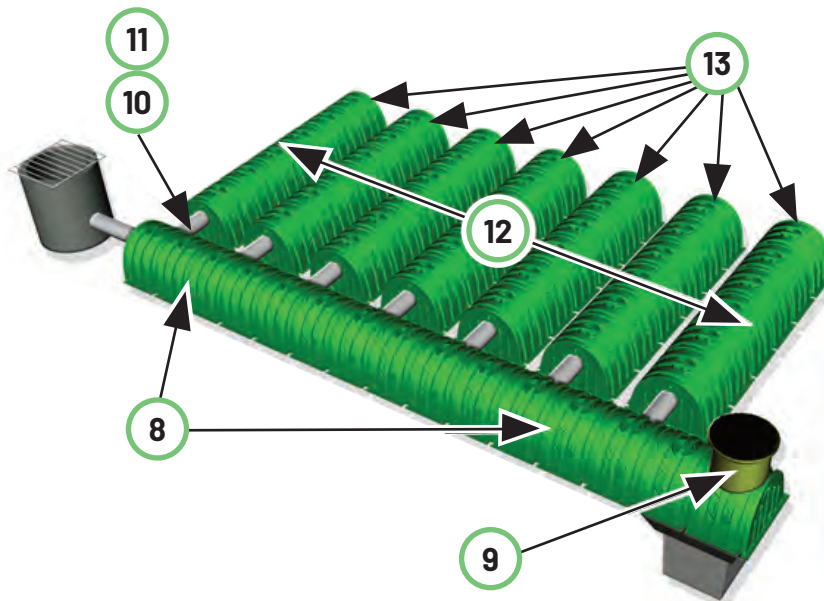

> Requirements for Assembling the HydroChain Main Header Row System (Cont.)

FIGURE 4



\*NOTE: A jig saw works the best to cut hole in end cap

1. Cut Proper Hole diameter on end cap to accept distribution pipe at proper invert height.
2. Install End Cap onto first section of each row of chambers in the drain field.
3. Slide chamber with installed end cap over end of distribution pipe or place chamber with installed end cap and pass distribution pipe from inside of chamber through the end cap hole into the chamber side hole. Use self-expanding closed cell foam to seal around gaps between end cap and chamber(s).

FIGURE 5

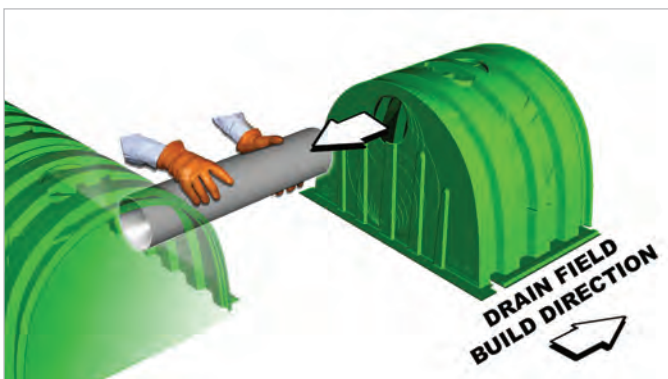

FIGURE 6



Figure 6 shows the distribution pipe projecting past the inside face of the end cap by a minimum of  $\frac{1}{2}$  the diameter of the inletting pipe.

Self-expanding closed cell foam can be used to fill in the gaps around the distribution pipe. Self expanding foam also can be used to fill in gaps around the pipes from the Main Header Row into the distribution rows (see figure 7).

FIGURE 7



The Main Header Row feeds water into the distribution rows.

> CONSTRUCTION GUIDE

TABLE 4 – Maximum Allowable Construction Vehicle Loads

Material Location See Figure 1	Fill Depth over Chambers in [mm]	Maximum Allowable Wheel Loads		Maximum Allowable Track Loads (see note 6)		Maximum Allowable Roller Loads
		Max Axle Load for Trucks lbs [kN]	Max Wheel Load for Loaders lbs [kN]	Track Width in. [mm]	Max Ground Pressure psf [kPa]	Max Drum Weight or Dynamic Force lbs [kN]
D Final Fill Material	36" [900] Compacted	48,000 [213]		12" [305]	3863 [185]	38,000 [169] Max Dynamic Force 20,000 lbs [53 kN]
				18" [457]	2652 [127]	
C Initial Fill Material	24" [600] Compacted	48,000 [213]	16,000 [71]	12" [305]	2715 [130]	Roller gross vehicle weight not to exceed 12,000 lbs [53 kN]  Max Dynamic Force 20,000 lbs [53 kN]
				18" [457]	1963 [94]	
				24" [610]	1587 [76]	
				30" [762]	1336 [64]	
	24" [600] Loose/ Dumped	48,000 [213]	16,000 [71]	12" [305]	2464 [118]	
				18" [457]	1775 [85]	
				24" [610]	1441 [69]	
				30" [762]	1232 [59]	
	18" [450]	48,000 [213]	16,000 [71]	12" [305]	2211 [106]	
				18" [457]	1628 [78]	
				24" [610]	1342 [64]	
				30" [762]	1166 [56]	
B Embedment Stone	12" [300]	16,000 [71]	NOT ALLOWED	12" [305]	1690 [81]	
				18" [457]	1219 [58]	
				24" [610]	1111 [53]	
				30" [762]	1000 [48]	
	6" [150]	8,000 [35]	NOT ALLOWED	NOT ALLOWED	12" [305]	924 [44]
					18" [457]	
					24" [610]	
					30" [762]	
						Walk-behind plate compactor whose compaction force does not exceed 2,500 lbs (10kN recommended)

NOTES:

- 36" (900 mm) of stabilized cover materials over the chambers is required for full dump truck travel and dumping.
- During paving operations, dump truck axle loads on 18" (450 mm) of cover may be necessary. Precautions should be taken to avoid rutting of the road base layer, to ensure that compaction requirements have been met, and that a minimum of 18" (450 mm) of cover exists over the chambers. Contact us at stormwater.eng@shawcor.com for additional guidance on allowable axle loads during paving.
- Ground pressure for track dozers is the vehicle operating weight divided by total ground contact area for both tracks. Excavators will exert higher ground pressures based on loaded bucket weight and boom extension.
- Mini-excavators (< 8,000lbs/3628 kg) can be used with at least 12" (300 mm) of stone over the chambers and are limited by the maximum ground pressures in Table 4, based on a full bucket at maximum boom extension.
- Storage of materials such as construction materials, equipment, spoils, etc. should not be located over the HydroChain chamber system. The use of equipment over the chamber system not covered in Table 4 (ex. soil mixing equipment, cranes, etc) is limited. Please contact us at stormwater.eng@shawcor.com for more information.
- Allowable track loads based on vehicle travel only. Excavators shall not operate on chamber beds until the total backfill reaches 3 feet (900mm) over the entire bed.**



Install non-woven geotextile over stone. Geotextile must overlap 12" (300mm) min. where edges meet. Compact each lift of backfill as specified in the site design engineer's drawings. Roller to travel parallel with rows.

TABLE 5 – Placement Methods and Descriptions

Material Location See Figure 1	Placement Methods/ Restrictions	Wheel Load Restrictions	Track Load Restrictions	Roller Load Restrictions
		See Table 4 for Maximum Construction Loads		
D Final Fill Material	A variety of placement methods may be used. All construction loads must not exceed the maximum limits in Table 4.	36" (900 mm) minimum cover required for dump trucks to dump over chambers.	Dozers to push parallel to rows until 36" (900mm) compacted cover is reached. <sup>4</sup>	Roller travel parallel to rows only until 36" (900 mm) compacted cover is reached.
C Initial Fill Material	Excavator positioned off bed is recommended. Small dozer or excavator are allowed as long as construction loads do not exceed maximum limits in Table 4.	Asphalt can be dumped into paver when compacted pavement subbase reaches 18" (450 mm) above top of chambers.	Small LGP track dozers & skid loaders allowed to grade cover stone with at least 6" (150 mm) stone under tracks at all times. Equipment must push parallel to rows at all times.	Use dynamic force of roller only after compacted fill depth reaches 12" (300 mm) over chambers. Roller travel parallel to chamber rows only.
B Embedment Stone	No equipment allowed on bare chambers. Use excavator or stone conveyor positioned off bed or on foundation stone to evenly fill around all chambers to at least 6" (150mm) above the top of the chambers	No wheel loads allowed. Material must be placed outside the limits of the chamber bed.	No tracked equipment is allowed on chambers until a min. 6" (150 mm) cover stone is in place.	No rollers allowed.
A Foundation Stone	No restrictions. Contractor responsible for any conditions or requirements by others relative to subgrade bearing capacity, dewatering or protection of subgrade			

**NOTES:**

1. 24" (610mm) MINIMUM DEPTH REQUIRED BETWEEN CASTING RIM AND TOP OF CHAMBERS (ASSUMING 4" (102mm) LOW-PROFILE CASTING WITH 1 ADJUSTING RING).
2. CONNECT STANDPIPE TO CHAMBER PER LATEST INSTALLATION INSTRUCTIONS.
3. CONNECTION OF THE STANDPIPE TO THE TOP SLAB IS TYPICALLY NOT NECESSARY. IF A CONNECTION IS DETERMINED TO BE NECESSARY, A FLEXIBLE CONNECTION IS REQUIRED.

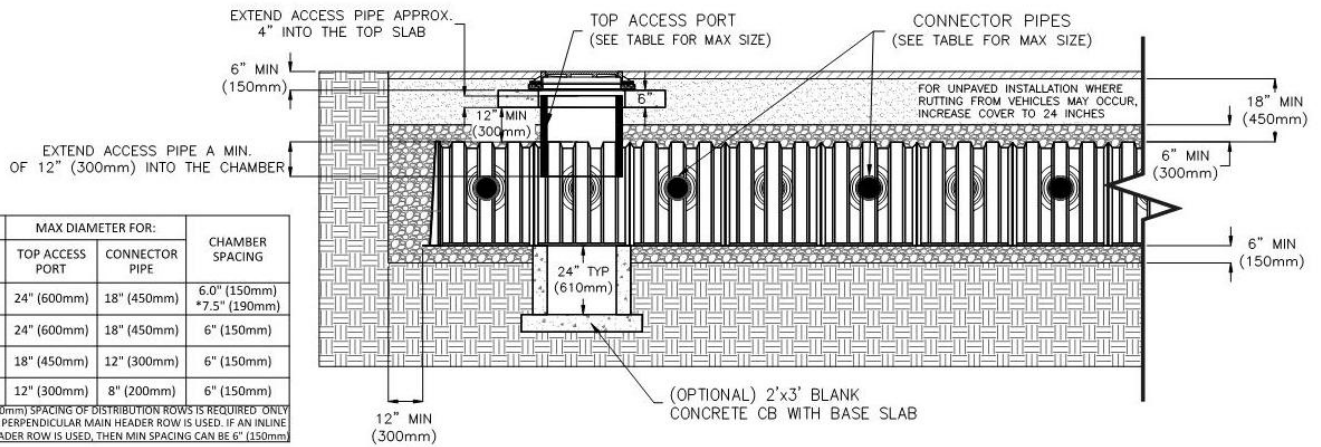
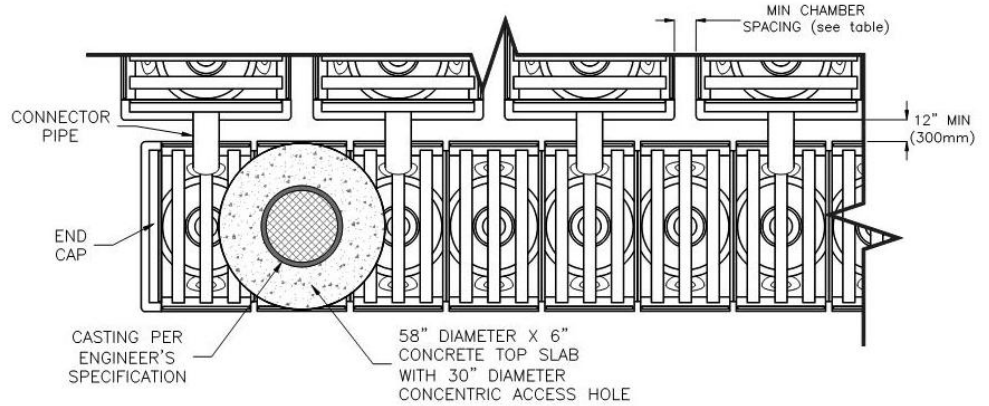

	MAX DIAMETER FOR:		CHAMBER SPACING
	TOP ACCESS PORT	CONNECTOR PIPE	
S29	24" (600mm)	18" (450mm)	6.0" (150mm) *7.5" (190mm)
S22	24" (600mm)	18" (450mm)	6" (150mm)
C10	18" (450mm)	12" (300mm)	6" (150mm)
M6	12" (300mm)	8" (200mm)	6" (150mm)

\*7.5" (190mm) SPACING OF DISTRIBUTION ROWS IS REQUIRED ONLY WHEN A PERPENDICULAR MAIN HEADER ROW IS USED. IF AN INLINE MAIN HEADER ROW IS USED, THEN MIN SPACING CAN BE 6" (150mm)

## > Backfill of Chambers – Embedment Stone

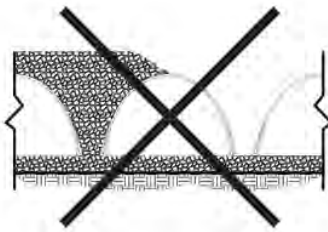

UNEVEN BACKFILL



EVEN BACKFILL

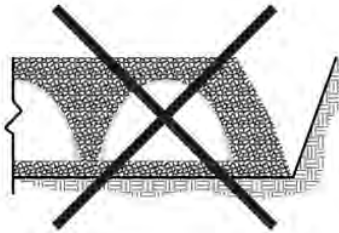

PERIMETER NOT BACKFILLED

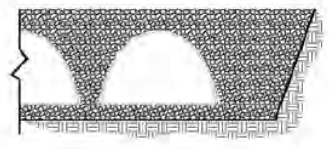

PERIMETER FULLY BACKFILLED

Backfill chambers evenly. Stone column height should never differ by more than 12" (300 mm) between adjacent chamber rows or between chamber rows and perimeter.

Perimeter stone must be brought up evenly with chamber rows. Perimeter must be fully backfilled, with stone extended horizontally to the excavation wall.

**Backfilling the system in this manner could result in damage – not recommended.**

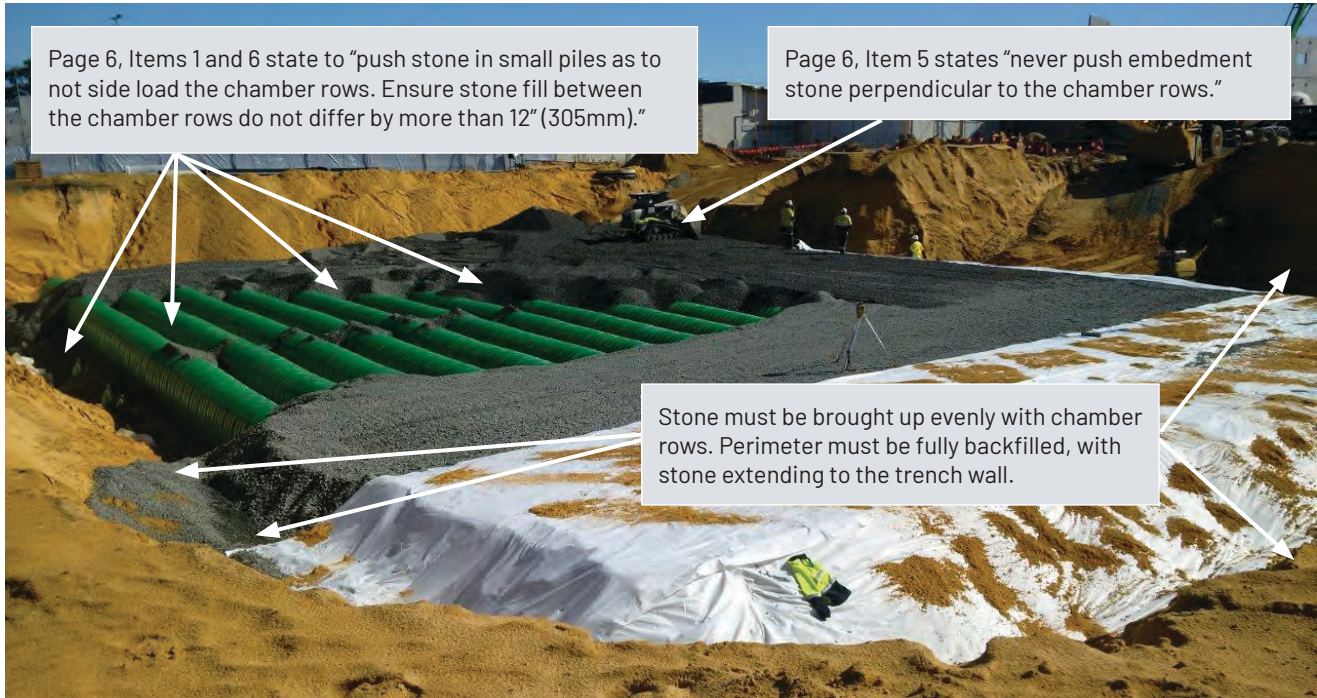

Non-recommended backfilling of system.

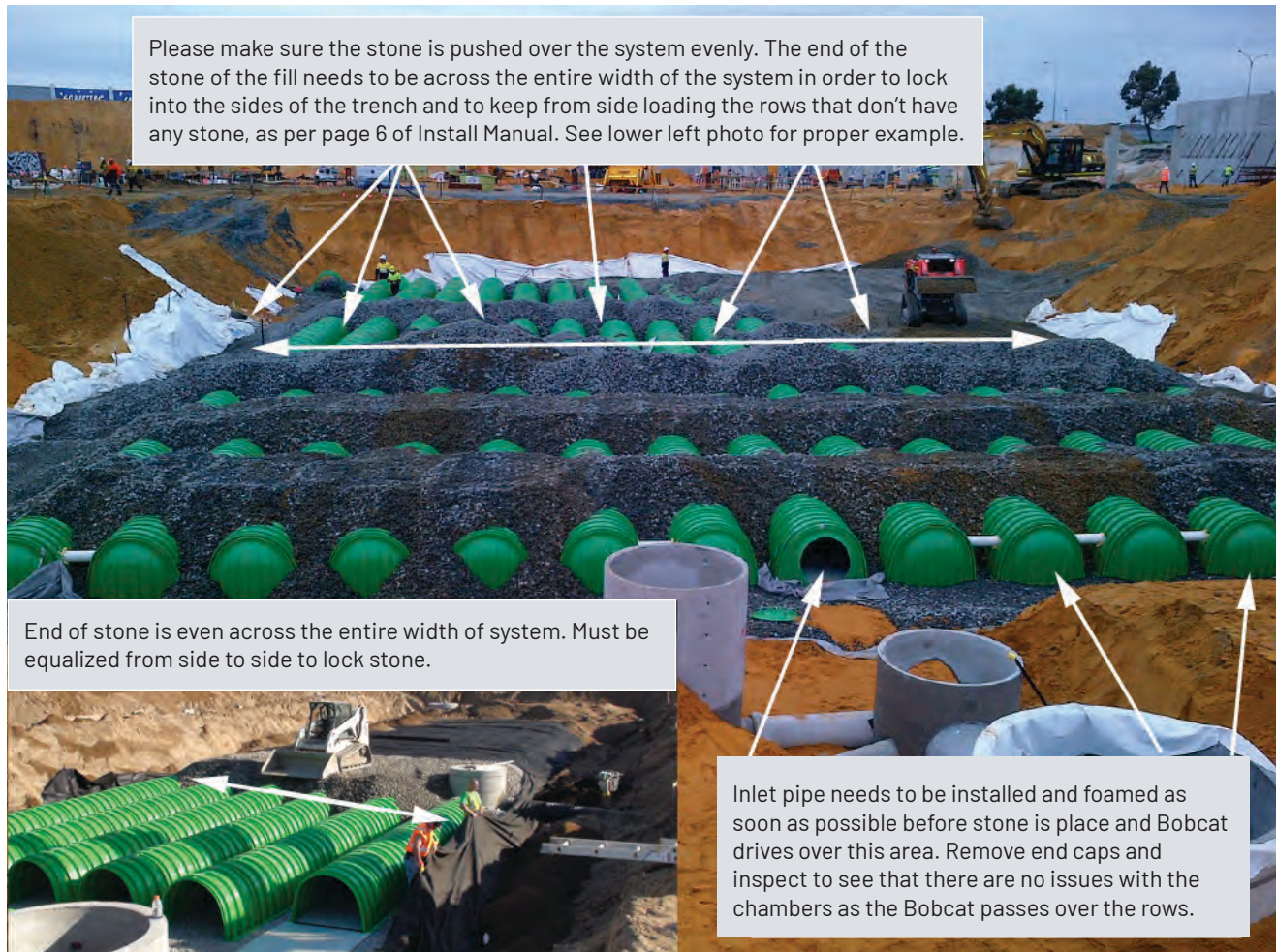



## > PROPER STONE USAGE



The stone shown above shows a mixture of clean, angular stone that ranges between .75" (9mm) to 2.0" (50mm) in size. This is an example of the specified stone that we require. Please refer to page 9 of this manual for further details.



The stone shown above is a nominal .75" (19.0mm) that had a lot of fines mixed in. Because it is not of mixed size and is of a smaller nominal size than what is called out for in our stone specification, this stone is not acceptable to use.



The picture above shows the layout and name of the components of the HydroChain chamber system.



As shown above, the use of a Telebelt truck is highly recommended. This type of truck will allow the placement of all the HydroChain chamber system products, connecting pipes, fabric, inlets and prior to backfilling. These trucks can easily convey up to 360 cu. ft. (10.2m<sup>3</sup>) of stone per hour without any damage to the products. This is a **quickest and safest way of backfilling the HydroChain chamber system.**



If using an excavator to cast the stone over the system, please make sure that you do not exceed the reach of the excavator. Ensure that the stone is evenly placed over the rows and that the stone column height never differs by more than 12" (300mm) between adjacent chambers rows or between chamber rows and perimeter. Refer to the Backfill of Chambers-Embedment Stone picture on page 15 of this manual.

## COMPLETE STORMWATER SYSTEMS



### MINI | Model: M-6

34" W x 17.5" H x 32" L 12 lbs  
863.6mm x 44.5mm x 812.8mm 6.8 kg.

Bare Chamber Storage 5.6 cf (.16 m<sup>3</sup>)  
With 6" (160mm) Stone Above and  
Below 11.5 cf (.326 m<sup>3</sup>)



### COMPACT | Model: C-10

40" W x 25" H x 32" L 15 lbs  
1016mm x 635mm x 812.8mm 6.8 kg.

Bare Chamber Storage 9.8 cf (.28 m<sup>3</sup>)  
With 6" (160mm) Stone Above and  
Below 17.6 cf (.498 m<sup>3</sup>)



### MEGA | Model: S-22

55" W x 35" H x 30" L 28 lbs  
1397mm x 863.6mm x 762mm 12.7kg

Bare Chamber Storage 23.2 cf (.66 m<sup>3</sup>)  
With 6" (150mm) Stone Above and  
Below 33.8 cf (.96 m<sup>3</sup>)



### ULTIMATE | Model: S-29

59" W x 36" H x 35" L 37 lbs  
1498.6mm x 914.4mm x 889mm 14.5 kg.

Bare Chamber Storage 29 cf (.82 m<sup>3</sup>)  
With 6" (160mm) Stone Above and  
Below 41.1 cf (1.161 m<sup>3</sup>)

For technical and engineering support, contact us at [stormwater.eng@shawcor.com](mailto:stormwater.eng@shawcor.com).



# CARING FOR WATER AROUND THE WORLD

No matter where in the world you need to manage and treat stormwater, we have the expertise and technology to meet your requirements.



[www.shawcor.com](http://www.shawcor.com)

[watersales@shawcor.com](mailto:watersales@shawcor.com)

© 2021 Shawcor Ltd. All rights reserved.

HCTCM0821