

Float Switch Settings and Adjustments

Before You Begin

Part 1 of these instructions provides basic information on how to make initial float switch settings for pump vaults and tanks in the absence of guidance from site plans, specifications, or applicable regulations regarding dosing, surge, and reserve volumes.

Part 2 of these instructions explains how to physically adjust the position of float switches on an Orenco[®] float switch assembly. For information on float switch settings and adjustments for AdvanTex[®] systems (“recirc” float switch settings), see NIN-ATX-DA-1, *Float Switch Settings and Adjustments: Residential AdvanTex Systems*.

Part 1: Guidelines for Initial Float Switch Settings

Float switch settings are the vertical distances from a common point of reference on the tank’s outside top to the set screw on the collar of individual float switches. They are used to control alarms and pump operations. Float switch settings are typically based on the needed or required volumes for the corresponding functions operated by the control panel, such as initiating a pumping event, engaging a timer, or triggering an alarm.

Absent all site plans, specifications, regulations, and any other information, Orenco recommends the following initial float switch settings for the systems listed in these instructions. Once you’ve determined the dose volume or timer settings, it is important to assess the necessary volumes between the float switches and adjust them accordingly.

Single-Pump (Simplex) Systems, Demand-Dose

- ❶ **High-Level Alarm:** 1½-3½ inches (38-89 mm) below the tank inlet’s invert.
- ❷ **Pump On or Pump On/Off:** 2 inches (50 mm) below the High-Level Alarm.
- ❸ **Pump Off (if used):** 2½ inches (64 mm) below the switch above it.
 - Set this switch at least 5 inches (127 mm) above the top of the filter cartridge if a Redundant Off/Low-Level Alarm (R/O) is used, at least 3 inches (75 mm) above the top of the filter cartridge if an R/O float switch is not used.
- ❹ **Redundant Off/Low-Level Alarm (if used):** At least 2 inches (50 mm) below the switch above it.
 - Set this switch at least 3 inches (75 mm) above the top of the filter cartridge.
 - Make sure this float is above the pump’s minimum liquid level.

Single-Pump (Simplex) Systems, Timed-Dose

- ❶ **High-Level Alarm or High-Level Alarm/Timer Override:** 1½-3½ inches (38-89 mm) below the tank inlet’s invert.
- ❷ **Timer Override or Timer On/Off (if used) :** 2 inches (50-mm) below the High-Level Alarm.
- ❸ **Timer On/Off:** Set at the distance below the override float that equals an average day’s flow for the system.
 - Determine the average day flow for the system.
 - Determine the gallons per inch (liters per mm) for the tank or basin.

(Continued on next page.)

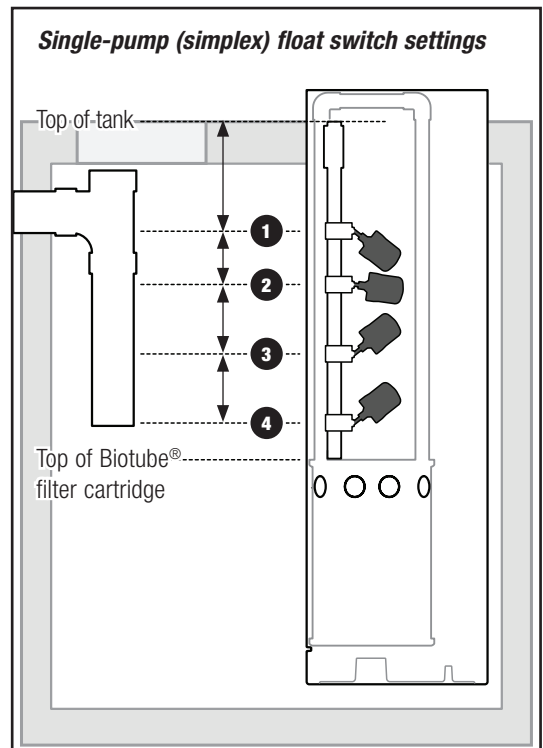
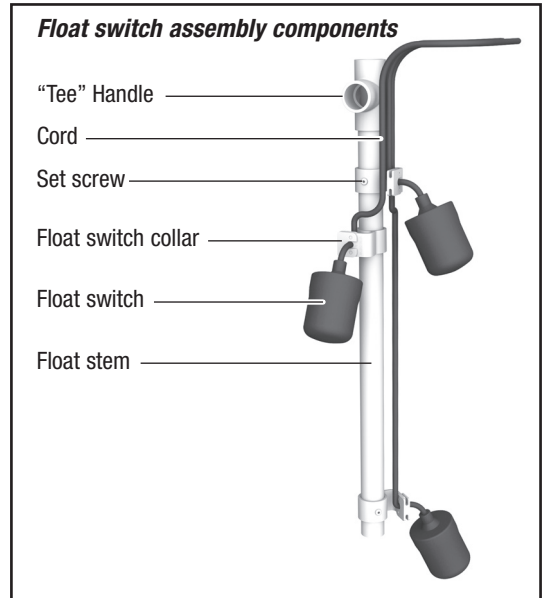

Single-Pump (Simplex) Systems, Timed-Dose, cont.

- Divide average day flow by gallons per inch or liters per mm of the tank chamber or basin to determine the necessary distance from the Timer On/Off to the float above it.
- Set this switch at least 4½ inches (114 mm) above the top of the filter cartridge if a Redundant Off/Low-Level Alarm (R/O) is used, at least 3 inches (75 mm) above the top of the filter cartridge if an R/O float switch is not used.

4 Redundant Off/Low-Level Alarm (if used): 3 inches (75 mm) below the switch above it.

- Set this switch at least 3 inches (75 mm) above the top of the filter cartridge.
- Make sure this float is above the pump's minimum liquid level.

Two-Pump (Duplex) Systems, Demand-Dose

1 High-Level Alarm or High-Level Alarm/Lag Pump Enable: 1½-3½ inches (38-89 mm) below the tank inlet's invert.

2 Lag Pump Enable (if used): 2 inches (50 mm) below the switch above it.

3 Lead Pump On: 2 inches (50 mm) below the switch above it.

4 Pumps Off: 1½ inches (38 mm) below the switch above it.

- Set this switch at least 5 inches above the top of the filter cartridge if a Redundant Off/Low-Level Alarm (R/O) is used, at least 3 inches (75 mm) above the top of the filter cartridge if an R/O float switch is not used.

5 Redundant Off/Low-Level Alarm (if used): 3 inches (75 mm) below the switch above it.

- Set this switch at least 3 inches (75 mm) above the top of the filter cartridge.
- Make sure this float is above the pump's minimum liquid level.

Two-Pump (Duplex) Systems, Timed-Dose

1 High-Level Alarm or High-Level Alarm/Lag Pump Enable: 1½-3½ inches (38-89 mm) below the tank inlet's invert.

2 Lag Pump Enable (if used) : 2 inches (50 mm) below the switch above it.

3 Timer Override: 2 inches (50 mm) below the switch above it.

4 Timer On/Off: Set at the distance below the override float that equals an average day's flow for the system.

- Determine the average day flow for the system.
- Determine the gallons per inch (liters per mm) for the tank or basin.
- Divide average day flow by gallons per inch or liters per mm of the tank chamber or basin to determine the necessary distance from the Timer On/Off to the float above it.
- Set this switch at least 4½ inches (114 mm) above the top of the filter cartridge if a Redundant Off/Low-Level Alarm (R/O) is used, at least 3 inches (75 mm) above the top of the filter cartridge if an R/O float switch is not used.

(Continued on next page.)

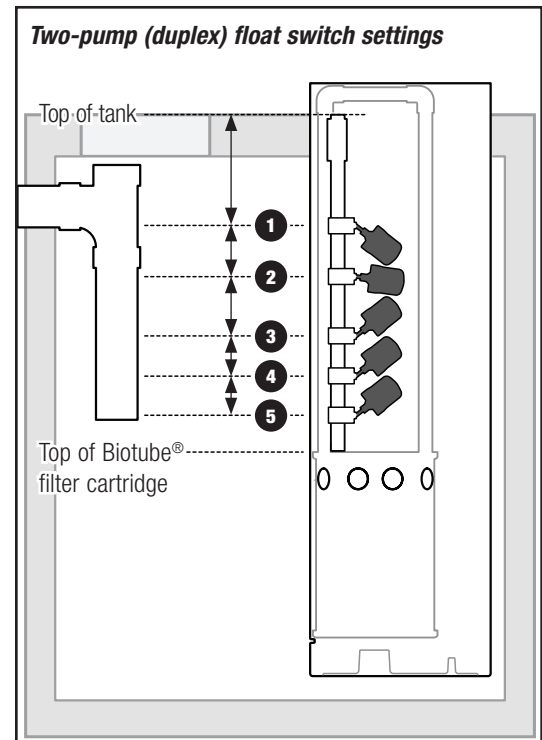

Two-Pump (Duplex) Systems, Timed-Dose, cont.

⑤ **Redundant Off/Low-Level Alarm (in four-switch systems):** 2½ inches (64 mm) below the switch above it.

- Set this switch at least 3 inches (75 mm) above the top of the filter cartridge.
- Make sure this float is above the pump's minimum liquid level.

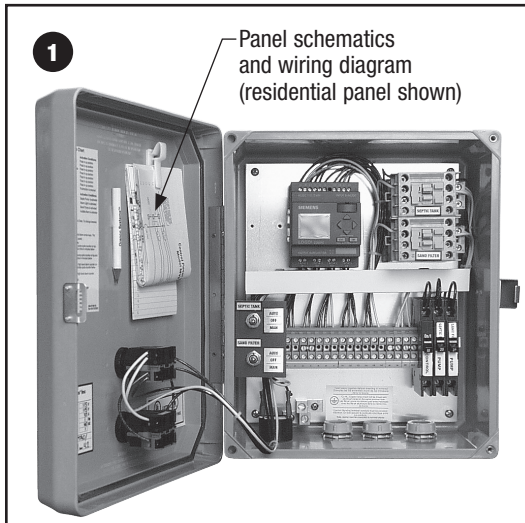

Part 2: Making Adjustments to Float Switches

Step 1: Check Float Switch Assembly

Check the assembly against the system's wiring diagram (located in the control panel).

- If you can't locate the wiring diagram, contact Orenco for a replacement.
- For information on 3-pump or 4-pump systems, contact your Distributor or Orenco.

Step 2: Verify Float Switch Settings

Step 2a: Measure the distance between the top of the pump vault and the top of the tank.

- Use the top of the tank as the common reference point for setting float switches.

Step 2b: Measure from the top of the pump vault down along the stem of the float switch assembly to the distance from Step 2a.

Step 2c: Mark that distance on the float stem.

- If measured and marked correctly, this mark should be level with the outside top of the tank and you can use it to measure float settings with the float switch assembly removed.

Step 2d: Remove the float switch assembly from the bracket.

Step 2e: Use the plans/specifications or applicable regulations and the reference mark on the stem to make sure the float switches are set correctly.

- If the settings don't match, adjust them according to the plans and specifications or applicable regulations.
- If there are no plans, specifications, or applicable regulations, use the general guidelines in this document to determine initial float settings for the system.
- For further assistance, call your Distributor or Orenco.

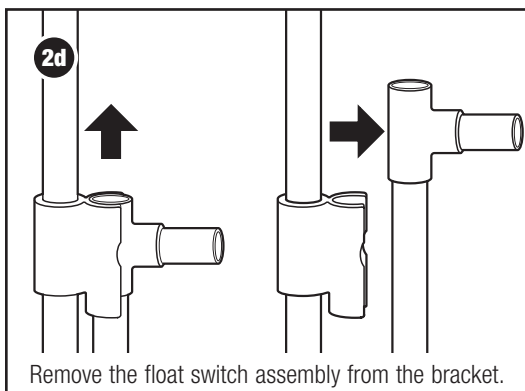
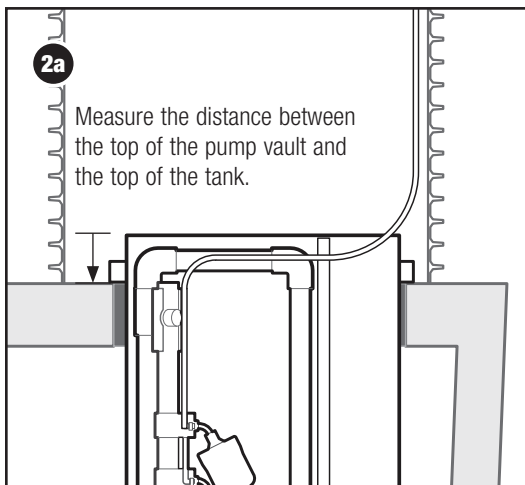

Step 3: Adjust Float Switch Settings

Step 3a: Loosen the set screw(s) on the float collar(s).

- Don't back the set screws completely out of the float collars.

Step 3b: Adjust the float collar(s) vertically to match the settings provided on the plans or in applicable regulations.

- For existing systems, vertically adjust the collar as necessary to meet discharge volume needs as described in the plans/specifications or applicable regulations.

Step 3c: Check for vertical and horizontal clearance between the float switches and between the float switches and the walls of the vault or basin.

- Move each float through its range of vertical motion.
- The float switches shouldn't interfere with one another during this check.

Step 3d: If the float switches interfere with another, adjust the collar horizontally until the float switch is clear of the float switch(es) above or below it.

Step 3e: When the float switch(es) are adjusted and have vertical and horizontal clearance, tighten the set screw(s).

Step 3f: Reinstall the float switch assembly back into the float bracket and use the reference mark to set the float switch assembly at the correct distance from the outside top of the tank.

- Make sure that the walls of the vault or basin don't interfere with the movements of the float switches. If they do, remove the float switches and readjust their horizontal clearances.

