

ClickTight™ & ClickTight Control Panel

Installation Instructions

Before You Begin

IMPORTANT:

- If you are installing a ClickTight™ Controls Package or a Prelos™ Processor, these instructions replace the installation instructions included inside the control panel.
- Be certain the number of float switches supplied matches the number of float switch female plugs on the ClickTight. Stop and contact your distributor regarding any differences.
- Instructions for making adjustments to panels equipped with pump timers are found inside the control panel.

Control panels should only be installed by a qualified professional with appropriate electrical licensing or certification. Read these instructions thoroughly before beginning the installation. Not performing the installation in accordance with these instructions may void Orenco® product warranties. Contact your distributor if there is a difference between these instructions and any applicable regulations. Inspect the order for all necessary parts and check that none of the equipment was damaged during shipment. Contact your distributor if parts are missing or damaged.

Step 1. Mount Control Panel

Step 1a: Calculate the allowable distance between the ClickTight connector and the control panel.

- Confirm the length of the ClickTight cable – typical length is 62 ft (19 m).
- Allow for depth of bury.
- Allow for conduit and cable bends.
- Allow for a panel mounting height of 4-5 ft (1.2-1.5 m) above finished grade.
- Allow for enough loose cable to make control panel wiring easy.

Step 1b: Choose a location for the panel within the allowable distance and within line of sight of the access riser that will house the ClickTight.

Step 1c: Mark the trench location between the ClickTight and the control panel.

Step 1d: Install the panel mounting bracket at the chosen location on a post or exterior wall.

IMPORTANT: DO NOT mount the control panel on an exterior wall other than a garage or shop wall! The motor contactor makes a sound while engaging and disengaging that can be disruptive to residents.

- Orenco recommends installing the panel on a 4x4-in. (100x100-mm) pressure-treated post, secured in concrete, with a mounting bracket at 4-5 ft (1.2-1.5 m) above finished grade.

Step 1e: Mount the control panel to the mounting bracket with stainless steel screws or lag bolts (not provided).

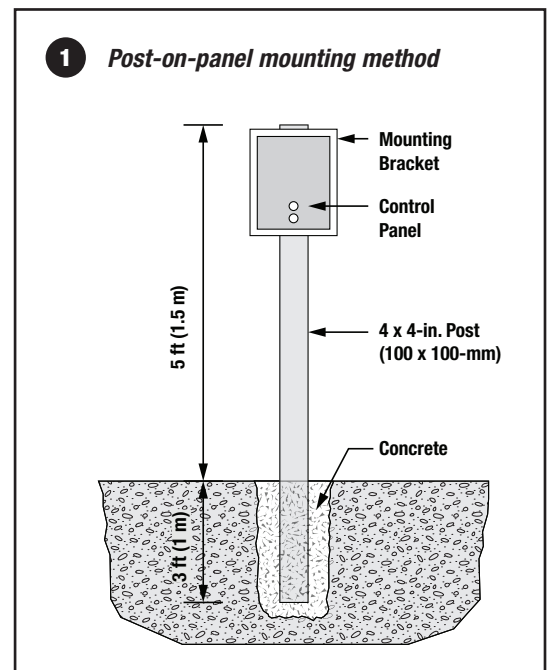

Step 2. Install ClickTight™ Coupler

Note: If the riser has been pre-drilled for the coupler, skip to Step 2d.

Step 2a: Measure and mark the location on the riser for the coupler penetration.

- The typical location is at the point on the riser nearest the control panel, 7 in. (178 mm) down from the riser's top.

Step 2b: Use a 2-in (50-mm) hole saw, centered on the mark, to drill the penetration.

Step 2c: Clean and deburr the penetration.

- Don't enlarge the penetration.

Step 2d: Make sure the o-ring is installed on the riser side of the coupler.

Step 2e: Apply a continuous bead of ADH200 adhesive to the riser side of the coupler.

Step 2f: Press the coupler firmly into the penetration from inside of the riser.

- Be sure the coupling's slot and tab are pointed toward the riser's top.

Step 2g: Secure the coupler to the riser wall with the supplied screws through the coupler's two screw holes.

- Don't overtighten the screws.

Step 3. Route Conduit

Note: If trenching for conduit and wire runs has been performed, skip to Step 3b.

Step 3a: Excavate a run from the control panel location to the ClickTight location.

- Orenco recommends a minimum 2-ft. (0.6-m) burial depth from finished grade for conduit/wiring installation.

Step 3b: Glue the supplied 1¼- to ¾-in. reducer into the ClickTight coupler.

- The ClickTight is made of ABS. Do not use primer on the ClickTight.
- A 1¼- to 1-in. reducer (not provided) can be installed in the coupler for installations requiring 1-in. conduit.

Step 3c: Run and connect electrical conduit from the reducer on the ClickTight coupler to the control panel location.

- All connections between the reducer and panel can be glued at this time.
- Conduit hubs are not provided with the control panel.

Step 4. Install ClickTight Connector

IMPORTANT: Avoid getting the connector wet during threading and installation. Don't drop or jostle the connector while threading cable or installing the connector.

Step 4a: Starting inside the riser, thread the ClickTight cable through the coupler to the control panel.

- Pull all of the cable through to the panel; leave no excess cable at the coupler.

Step 4b: Align the connector so the screw tab points to the top of the riser.

Step 4c: Firmly press the connector into the coupler until they fit together snugly.

Step 4d: Secure the connector to the coupler with the supplied screw.

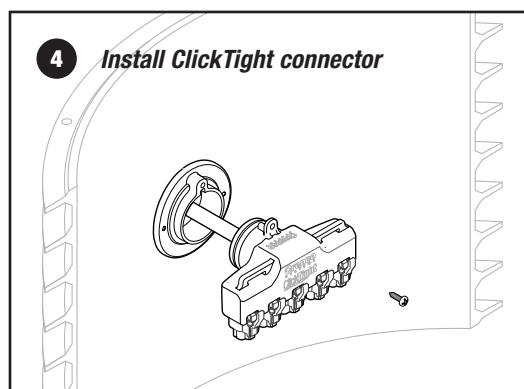
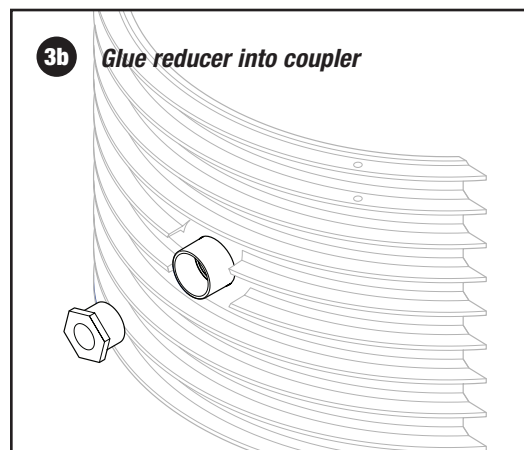
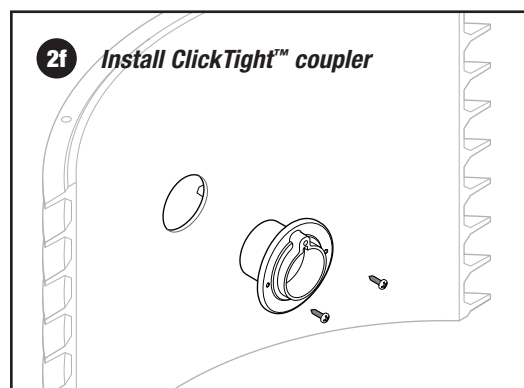
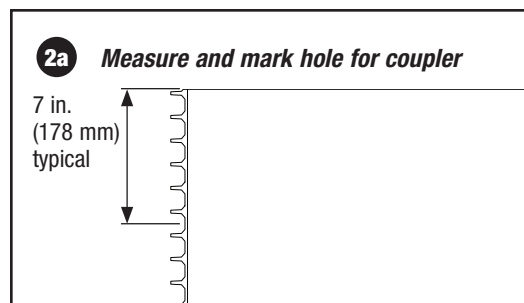

Step 5: Make Panel Wiring Connections**Notes:****• MVP Panels**

Time-Dosed Mode: Place the supplied terminal link between terminals 3 and 4.

On-Demand Mode: Place the supplied terminal link between terminals 2 and 3.

- Some panels have two common terminals that share a terminal link. Do not remove this terminal link when wiring.
- S1RO panels may require the removal of a terminal link, depending on float configuration. Reference the panel wiring diagram when wiring control panels.

Step 5a: Check the panel's model number, located on the inside of the control panel door, for the "RO" feature.

- Panels with an "RO" in the model number have the "redundant-off" feature.
- RO panels are wired differently than non-RO panels.

Step 5b: Make float switch wiring connections in the panel, based on the presence or absence of the "RO" feature and the number of float switches in the system.

Non-RO Panel, 2 Float Switches

- Identify ClickTight cable wiring pairs in each of the following colors: blue, yellow.
- Install each colored wire into a corresponding, colored terminal in the control panel, one wire per terminal.

Non-RO Panel, 3 Float Switches

- Identify ClickTight cable wiring pairs in each of the following colors: orange, blue, yellow.
- Install each colored wire into a corresponding, colored terminal in the control panel, one wire per terminal.

RO Panel, 3 Float Switches

- Identify ClickTight cable wiring pairs in each of the following colors: orange, blue, yellow.
- Install one each of the colored wires into the corresponding, colored terminal in the control panel.
- Install the remaining colored wires into the two #5 terminals: two wires in one terminal, one in the other.

RO Panel, 4 Float Switches

- Identify ClickTight cable wiring pairs in each of the following colors: orange, blue, brown, yellow.
- Install one each of the colored wires into the corresponding, colored terminal in the control panel.
- Install the remaining colored wires into the two #5 terminals, two wires per terminal.

Step 5c: Make the pump wiring connections in the panel.

- Wire the black ClickTight cable wire to the black pump terminal.
- Wire the white ClickTight cable wire to the white pump terminal.
- Connect the green ClickTight cable wire to the grounding lug on the panel's backplate.

Step 6: Connect Plugs to ClickTight

Step 6a: Connect the pump cord plug to the ClickTight's center plug.

- Be sure the plugs connect securely.

Step 6b: Connect the float switch cord plugs to the corresponding ClickTight plugs, from the top switch in the float switch assembly to the bottom switch.

2-Switch Assemblies

- Locate the cord plug for the top float switch in the float switch assembly and connect it to the ClickTight plug labeled "yellow."
- Locate the cord plug for the bottom float switch in the float switch assembly and connect it to the ClickTight plug labeled "blue."

3-Switch Assemblies

- Locate the cord plug for the top float switch in the float switch assembly and connect it to the ClickTight plug labeled "yellow."
- Locate the cord plug for the middle float switch in the float switch assembly and connect it to the ClickTight plug labeled "blue."
- Locate the cord plug for the bottom float switch in the float switch assembly and connect it to the ClickTight plug labeled "orange."

4-Switch Assemblies

- Locate the cord plug for the top float switch in the float switch assembly and connect it to the ClickTight plug labeled "yellow."
- Locate the cord plug for the upper middle float switch in the float switch assembly and connect it to the ClickTight plug labeled "brown."
- Locate the cord plug for the lower middle float switch in the float switch assembly and connect it to the ClickTight plug labeled "blue."
- Locate the cord plug for the bottom float switch in the float switch assembly and connect it to the ClickTight plug labeled "orange."

6 **Connect plugs to ClickTight™**

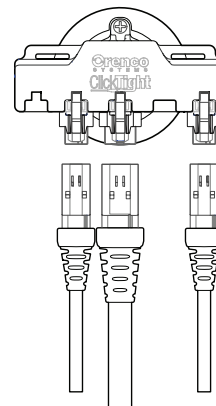

2-float switch configuration

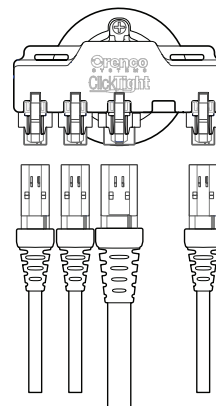

3-float switch configuration

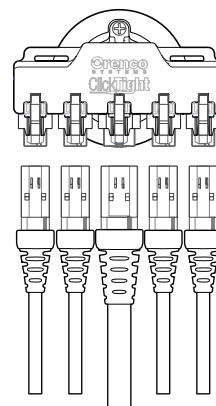

4-float switch configuration

Step 7. Test Control Functions

Step 7a: Check for the following before beginning testing ...

- The float switch assembly is correctly installed.
- The float switch elevation settings match the settings provided on the plan set or engineering drawing.
- The pump cord and float switch connectors are fully plugged into the ClickTight, and the ClickTight cable is wired into the control panel.
- The wiring between the control panel and service panel is connected, and the voltage to the control panel is correct.
- The pump tank's liquid level is above the pump's minimum liquid level (MLL). If it isn't, fill the tank to above the pump's MLL.
- All connections are made between the building sewer, tank inlet, tank discharge, and transport line.
- Check the panel's model number, located on the inside of the control panel door, for the "PT" feature.
 - Panels with a "PT" in the model number have the "pump timer" feature.
 - When a pump timer-controlled float switch activates, the pump will not turn on until the timer countdown is complete.
 - Be aware of this feature when testing panels equipped with pump timers.

Step 7b: Remove the float switch assembly from the tank and place all of the float switches in the "down" position.

Step 7c: Set the control panel's Auto/Off/Man switch to "Off."

Step 7d: Turn on the control and pump circuit breakers in the control panel.

Step 7e: Set the control panel's Auto/Off/Man switch to "Auto" and test float switch function, from bottom to top.

2-Switch Assemblies

- Pump On/Off switch (Timer On switch for panels equipped with pump timers): Up position activates the pump or begins the timer cycle; down position deactivates the pump or resets the timer cycle. Keep this switch in the down position for the rest of this test.
- High-Level Alarm switch: Up position activates the alarm; down position deactivates the alarm.

3-Switch Assemblies with Redundant-Off

- Low-Level Alarm/Redundant-Off switch: Down position activates the alarm; up position deactivates the alarm. After testing this switch, keep it in the up position for the rest of the test.
- Pump On/Off switch (Timer On switch for panels equipped with pump timers): Up position activates the pump or begins the timer cycle; down position deactivates the pump or resets the timer cycle. Keep this switch in the down position for the rest of this test.
- High-Level Alarm switch: Up position activates the alarm; down position deactivates the alarm.

Step 7. Test Control Functions, cont.**3-Switch Assemblies without Redundant-Off**

- Pump Off switch: (Timer On switch for panels equipped with pump timers): Deactivates the pump in demand-dose systems; activates the pump timer in systems equipped with pump timers. Hold it in the up position for this test.
- Pump On switch (Override Timer On for panels equipped with pump timers): Up position activates the pump; pump stays activated when the switch is lowered. Lowering the Pump Off switch deactivates the pump.
- High-Level Alarm switch: Up position activates the alarm; down position deactivates the alarm.

4-Switch Assemblies

- Low-Level Alarm/Redundant-Off switch: Down position activates the alarm; up position deactivates the alarm. After testing this switch, keep it in the up position for the rest of the test.
- Pump Off switch (Timer On switch for panels equipped with pump timers): Up position allows Pump On switch to activate pump or begins Timer On cycle.
- Pump On switch (Timer Override switch for panels equipped with pump timers): Up position activates the pump. Pump On switch down and Pump Off switch up deactivates the pump. After testing, keep these switches in the down position for the rest of the test.
- High-Level Alarm switch: Up position activates the alarm; down position deactivates the alarm.

Step 7f: If all of the float switch functions operate correctly, make sure all switches are in the down position and reinstall the float switch assembly.

Step 7g: Set the control panel's Auto/Off/Man switch to "Off."

Step 8. Close and Secure Lids

Check that the tank or Processor's access lid(s) are closed and secure.

- *If the lid(s) are not secured, close and secure them before leaving the site.*