

AX25RT Treatment System - Pump Discharge

Filter Tank Dry Weight: 950 lbs

Design Notes

For residential strength waste up to 6 bedrooms.

Installation to be performed by an AdvanTex Authorized Installer only.

Start-up and service to be performed by an AdvanTex Authorized Service Provider only.

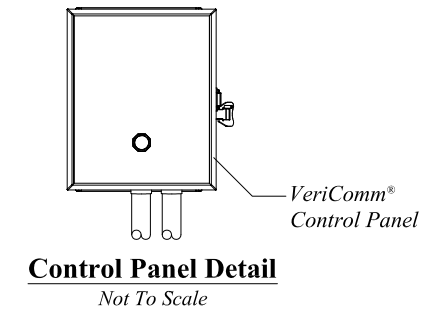
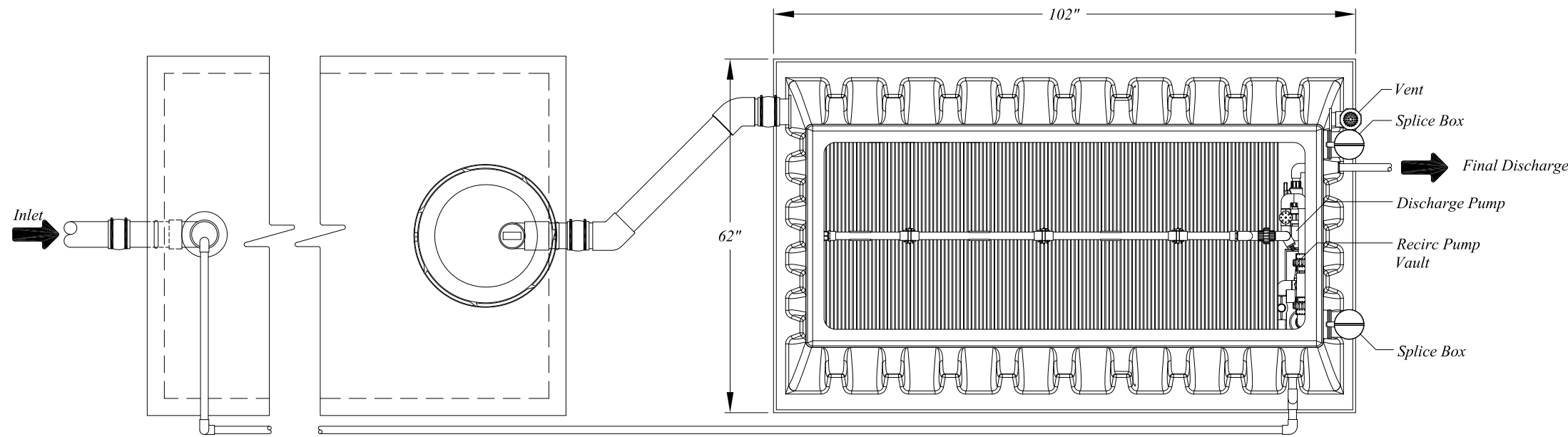

* Primary Tank - Top View

AX25 800 gal. Recirc. Tank - Top View

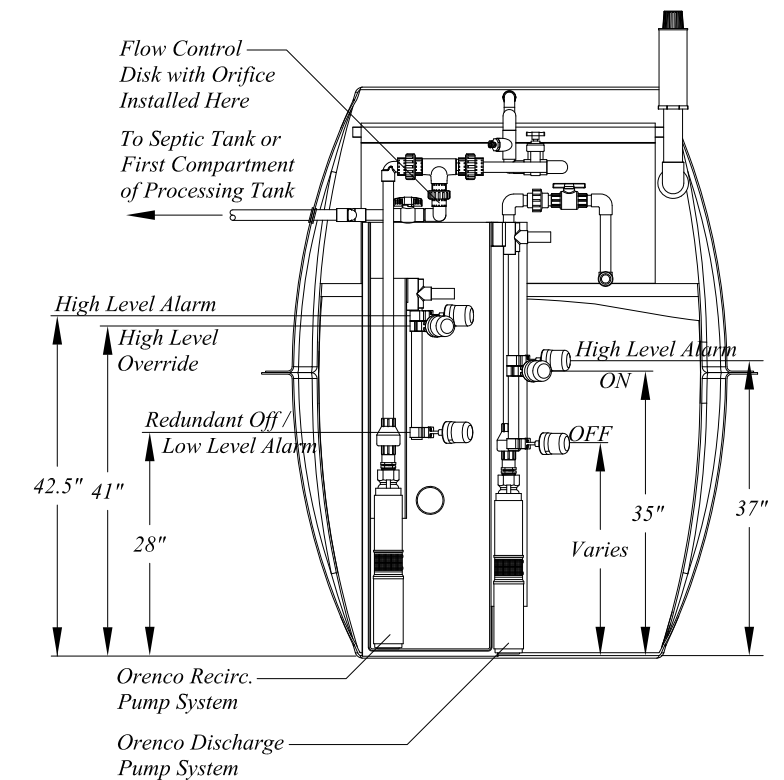
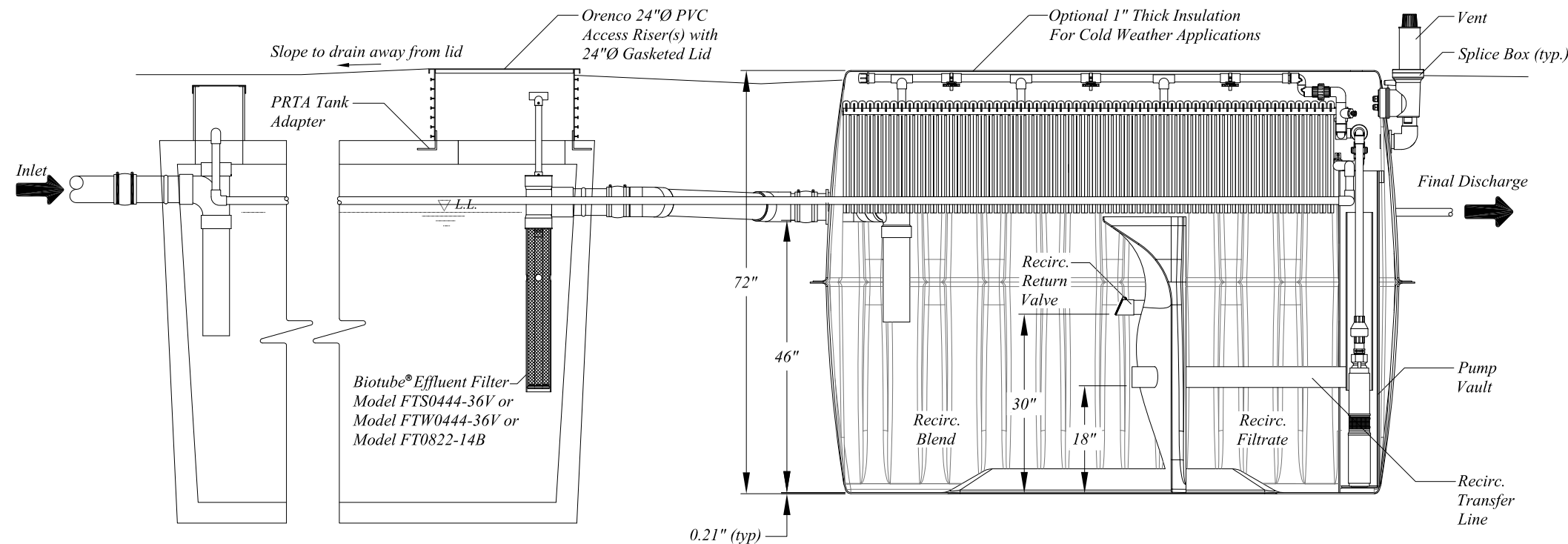

* Primary Tank - Side View

AX25 800 gal. Recirc. Tank - Side View

Discharge Chamber - End View

* 1,250 Gallons minimum capacity for 5 bedrooms
1,500 Gallons minimum capacity for 6 bedrooms.

Copyright © 2013
Orengo Systems®, Inc.

UNAUTHORIZED CHANGES & USES

Orengo has prepared these drawings for use by the design engineer. Orengo will not be responsible or liable for unauthorized changes to or uses of these drawings. All changes to these drawings must be made in writing and must be approved by the design engineer.

PRODUCT CONFIGURATION DRAWINGS



Drawn By: BEN SMITH

Drawn For:

Project:

AX25RT Mode 3B

Title:

NDW-ATX-RT-STD-25

Scale: 1" = 2'-0"

Sheet: 1 OF 1

Rev: A-02

Date: 4/22/2013