

NOTES:

1. INVERT DIMENSION FROM TANK I.D.
2. 14' PREFABRICATED CONCRETE DEADMEN ANCHOR POINTS ARE NOT SYMMETRICAL. NOTE THE POSITIONING WHEN INSTALLING.
3. 12' TANKS WITH A CAPACITY OF 20,000 U.S. GALLONS OR LARGER MAY REQUIRE LARGER DEADMEN THAN THOSE SHOWN, DEPENDING ON BURIAL DEPTH, TO OFFSET BUOYANCY.
4. NOMINAL TANK WEIGHT : 20,000 lbs.

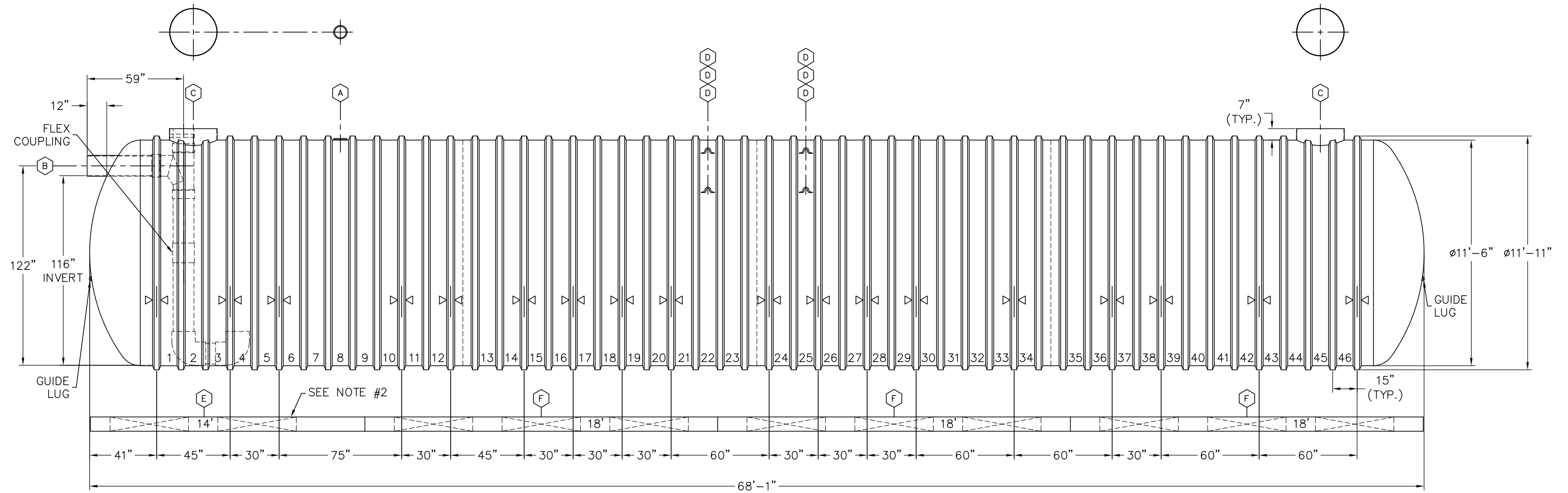

ITEM	QTY	DESCRIPTION
(A)	1	6"NPT SERVICE FITTING
(B)	1	12"DIA SCH 40 PVC INLET PIPE, INTERNAL SANITARY TEE & PIPES WITH SMOOTHING INLET & FLEXIBLE COUPLING
(C)	2	RISER PIPE, 29 3/8"O.D., FOR 30"(NOMINAL) ACCESS OPENING
(D)	6	LIFTING LUG (10"x10" HD) 24 1/16", 24 1/16", 60 3/16"
(E)	2	14' PREFABRICATED CONCRETE DEADMEN
(F)	6	18' PREFABRICATED CONCRETE DEADMEN
▷◁	18	HOLD DOWN STRAP LOCATION

00		REVISION DESCRIPTION			
DRN	DATE	CHK'D	DATE	APPR'D	DATE
LJB	3-2-21				
CHK'D	DATE	TITLE			
PWM	3-2-21	12' DIA SW			
APPR'D	DATE	CAP. 50,000 GALLONS			
		BIO SOLUTIONS			
SALES MANAGER		DR. SIZE	DR. NUMBER	REV	
DAVID HOLMES		B	668-362	00	
		SCALE:	N.T.S.	SHT 1 OF 1	
INDUSTRY TYPE: M204 WATER COLLECTION AND CONSERVATION					

NOTES:

1. INVERT DIMENSION FROM TANK I.D.
2. 12' TANKS WITH A CAPACITY OF 20,000 U.S. GALLONS OR LARGER MAY REQUIRE LARGER DEADMEN THAN THOSE SHOWN, DEPENDING ON BURIAL DEPTH, TO OFFSET BUOYANCY.
3. NOMINAL TANK WEIGHT : 16,100 lbs.

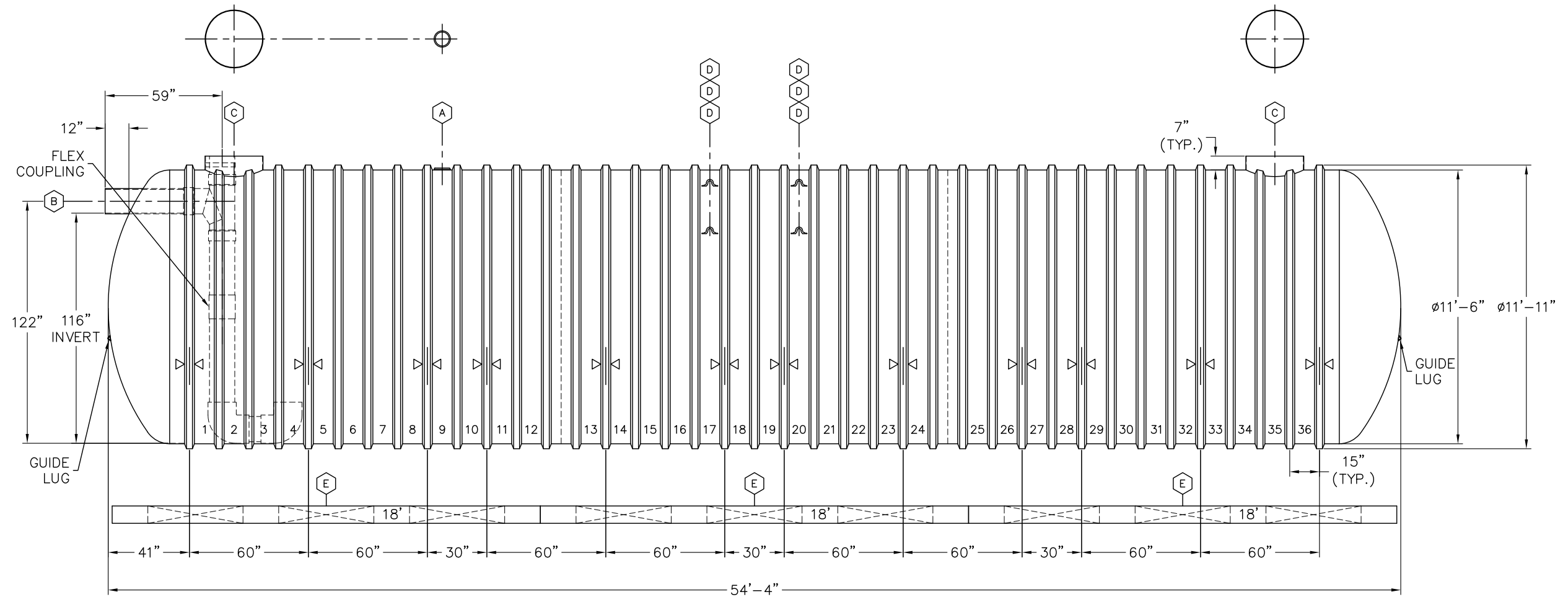

ITEM	QTY	DESCRIPTION
(A)	1	6"NPT SERVICE FITTING
(B)	1	12"DIA SCH 40 PVC INLET PIPE, INTERNAL SANITARY TEE & PIPES WITH SMOOTHING INLET & FLEXIBLE COUPLING
(C)	2	RISER PIPE, 29 3/8"O.D., FOR 30"(NOMINAL) ACCESS OPENING
(D)	6	LIFTING LUG (10"x10" HD) 24 1/16", 24 1/16", 60 3/16"
(E)	6	18' PREFABRICATED CONCRETE DEADMEN
▷◁	12	HOLD DOWN STRAP LOCATION

CUSTOMER DESIGNATION:  
RAINWATER CISTERN

00		REVISION DESCRIPTION			
DRN	DATE	CHK'D	DATE	APPR'D	DATE
<b>XERXES BY SHAWCOR</b>					
DRN	LJB	DATE	3-2-21	TITLE	12' DIA SW
CHK'D	PWM	DATE	3-2-21		CAP. 40,000 GALLONS
APPR'D	-	DATE	-		BIO SOLUTIONS
SALES MANAGER	DAVID HOLMES	DR. SIZE	B	DR. NUMBER	668-363
		SCALE	N.T.S.	REV	00
INDUSTRY TYPE: M204 WATER COLLECTION AND CONSERVATION					SHT 1 OF 1

- NOTES:
1. INVERT DIMENSION FROM TANK I.D.
  2. 14' PREFABRICATED CONCRETE DEADMEN ANCHOR POINTS ARE NOT SYMMETRICAL. NOTE THE POSITIONING WHEN INSTALLING.
  3. ESTIMATED TANK WEIGHT: 11,100 lbs.

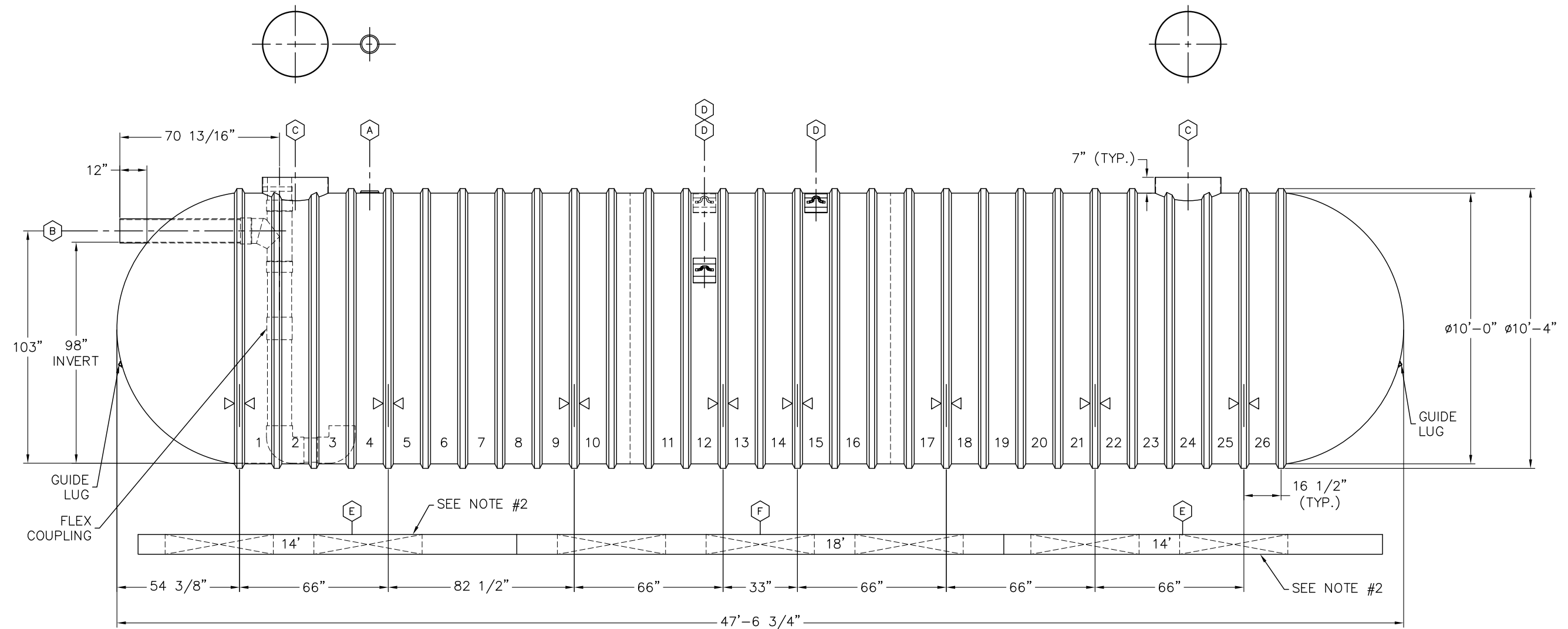

ITEM	QTY	DESCRIPTION
(A)	1	6"NPT SERVICE FITTING
(B)	1	10"DIA SCH 40 PVC INLET PIPE, INTERNAL SANITARY TEE & PIPES WITH SMOOTHING INLET & FLEXIBLE COUPLING
(C)	2	RISER PIPE, 29 3/8"O.D., FOR 30"(NOMINAL) ACCESS OPENING
(D)	3	LIFTING LUG (12" x 10") 22.5", 22.5", 45"
(E)	4	14' PREFABRICATED CONCRETE DEADMEN
(F)	2	18' PREFABRICATED CONCRETE DEADMEN
▷◁	8	HOLD DOWN STRAP LOCATION

CUSTOMER DESIGNATION:  
RAINWATER CISTERN

00		REVISION DESCRIPTION			
DRN	DATE	CHK'D	DATE	APPR'D	DATE
<b>XERXES BY SHAWCOR</b>					
DRN	LJB	DATE	3-3-21	TITLE	10' DIA SW
CHK'D	PWM	DATE	3-3-21		CAP. 25,000 GALLONS
APPR'D	-	DATE	-		BIO SOLUTIONS
SALES MANAGER	DAVID HOLMES	DR. SIZE	B	DR. NUMBER	668-364
		SCALE	N.T.S.	REV	00
INDUSTRY TYPE: M204 WATER COLLECTION AND CONSERVATION					SHT 1 OF 1

- NOTES:  
 1. INVERT DIMENSION FROM TANK I.D.  
 2. ESTIMATED TANK WEIGHT: 8,600 lbs.

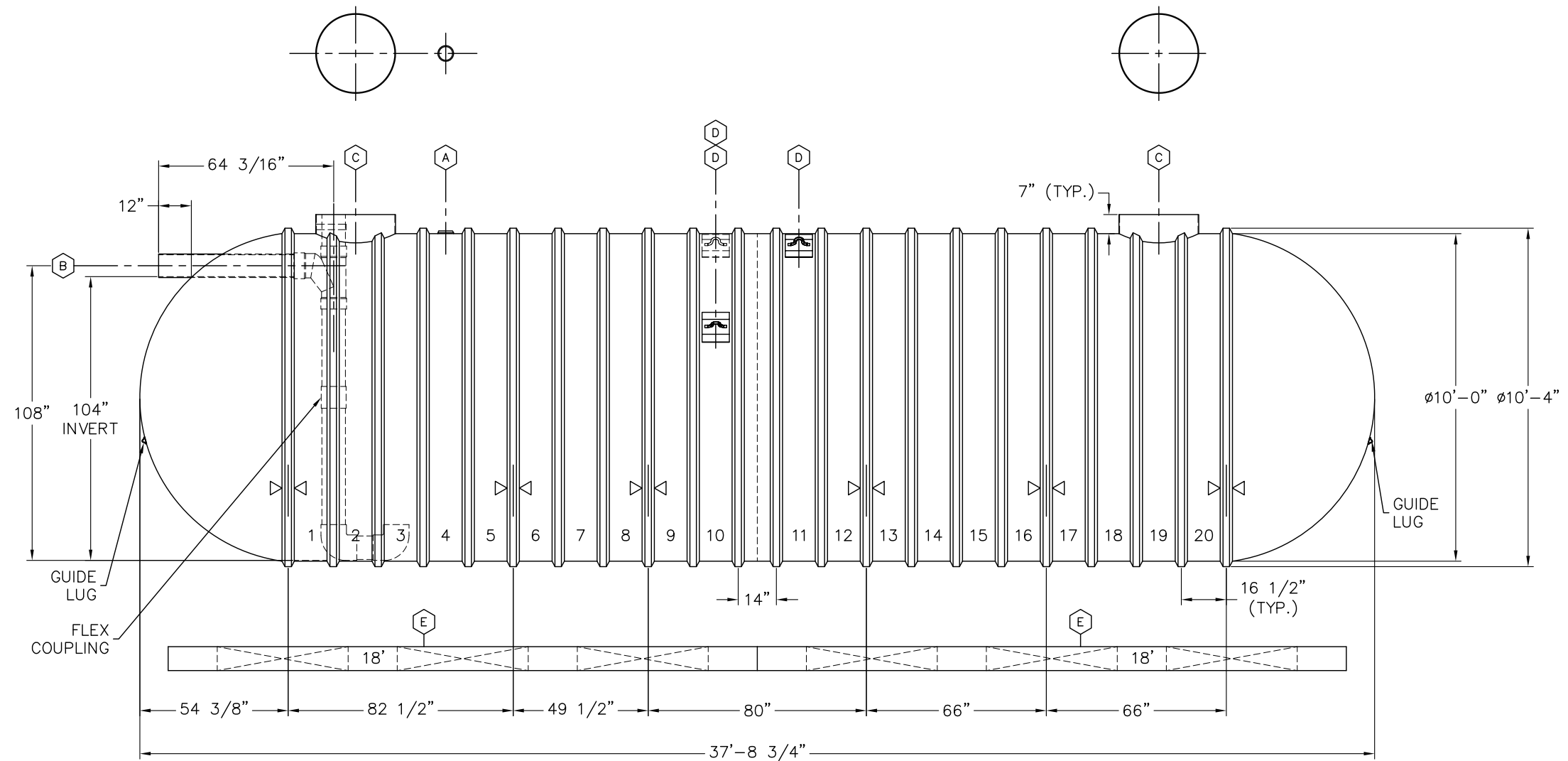

ITEM	QTY	DESCRIPTION
(A)	1	4"NPT SERVICE FITTING
(B)	1	8"DIA SCH 40 PVC INLET PIPE, INTERNAL SANITARY TEE & PIPES WITH SMOOTHING INLET & FLEXIBLE COUPLING
(C)	2	RISER PIPE, 29 3/8"O.D., FOR 30"(NOMINAL) ACCESS OPENING
(D)	3	LIFTING LUG (12" x 10") 22.5", 22.5", 45"
(E)	4	18' PREFABRICATED CONCRETE DEADMEN
▷◁	6	HOLD DOWN STRAP LOCATION

CUSTOMER  
 DESIGNATION:  
 RAINWATER CISTERN

00		REVISION DESCRIPTION			
DRN	DATE	CHK'D	DATE	APPR'D	DATE
<b>XERXES BY SHAWCOR</b>					
DRN	LJB	DATE	3-3-21	TITLE	10' DIA SW
CHK'D	PWM	DATE	3-3-21		CAP. 20,000 GALLONS
APPR'D	-	DATE	-		BIO SOLUTIONS
SALES MANAGER	DAVID HOLMES	DR. SIZE	B	DR. NUMBER	668-365
		SCALE	N.T.S.	REV	00
INDUSTRY TYPE: M204 WATER COLLECTION AND CONSERVATION					SHT 1 OF 1





NOTES:

1. INVERT DIMENSION FROM TANK I.D.
2. ESTIMATED TANK WEIGHT: 4,500 lbs.

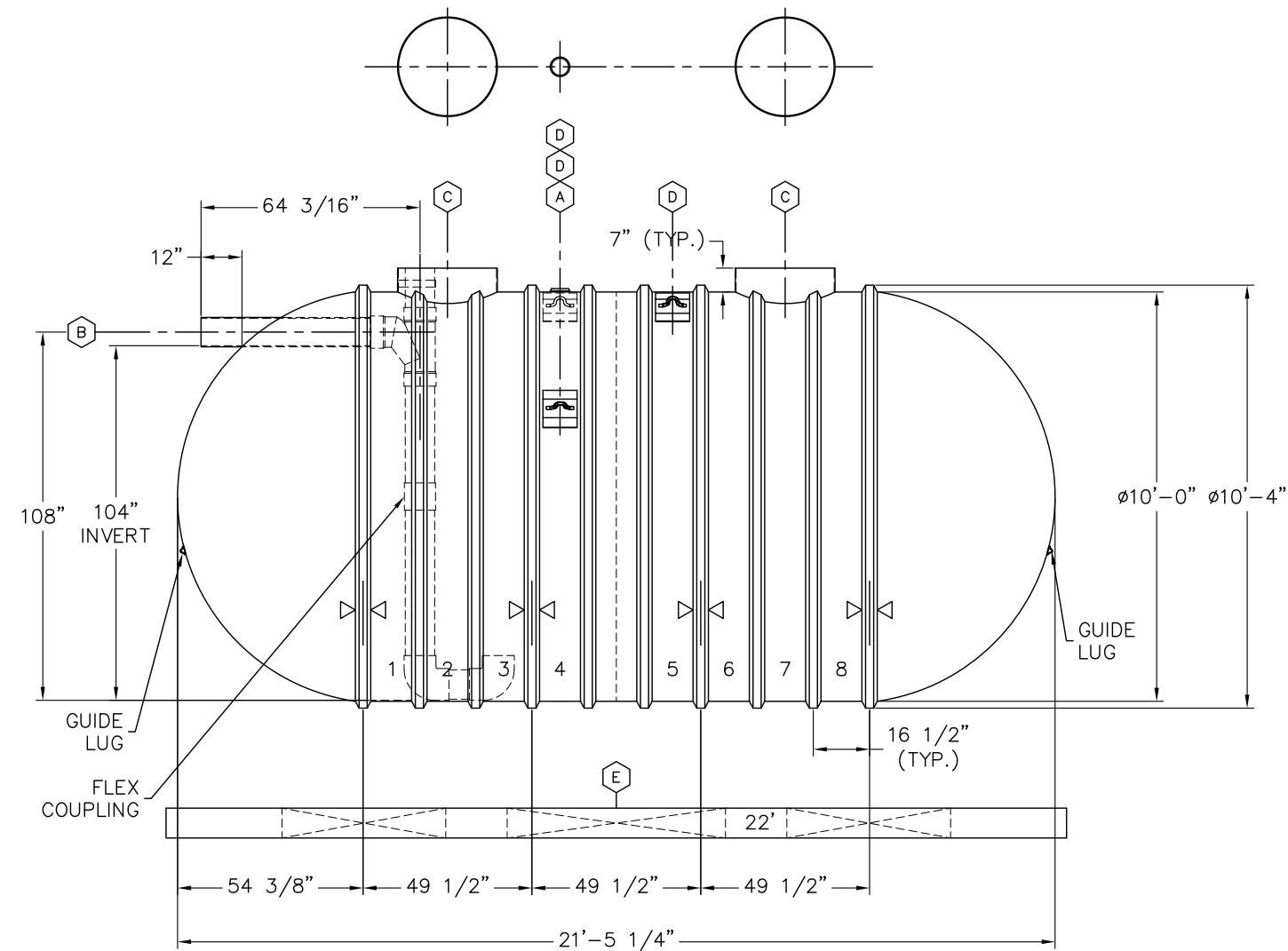

ITEM	QTY	DESCRIPTION
(A)	1	4"NPT SERVICE FITTING
(B)	1	8"DIA SCH 40 PVC INLET PIPE, INTERNAL SANITARY TEE & PIPES WITH SMOOTHING INLET & FLEXIBLE COUPLING
(C)	2	RISER PIPE, 29 3/8"O.D., FOR 30"(NOMINAL) ACCESS OPENING
(D)	3	LIFTING LUG (12" x 10") 22.5", 22.5", 45"
(E)	2	22' PREFABRICATED CONCRETE DEADMEN
▷◁	4	HOLD DOWN STRAP LOCATION

00		REVISION DESCRIPTION			
DRN	DATE	CHK'D	DATE	APPR'D	DATE
<b>XERXES BY SHAWCOR</b>					
DRN	LJB	DATE	3-3-21	TITLE	10' DIA SW
CHK'D	PWM	DATE	3-3-21		CAP. 10,000 GALLONS
APPR'D	-	DATE	-		BIO SOLUTIONS
SALES MANAGER		DR. SIZE	DR. NUMBER	REV	
DAVID HOLMES		B	668-368	00	
		SCALE	N.T.S.	SHT	1 OF 1
INDUSTRY TYPE: M204 WATER COLLECTION AND CONSERVATION					

- NOTES:  
 1. INVERT DIMENSION FROM TANK I.D.  
 2. ESTIMATED TANK WEIGHT: 5,100 lbs.

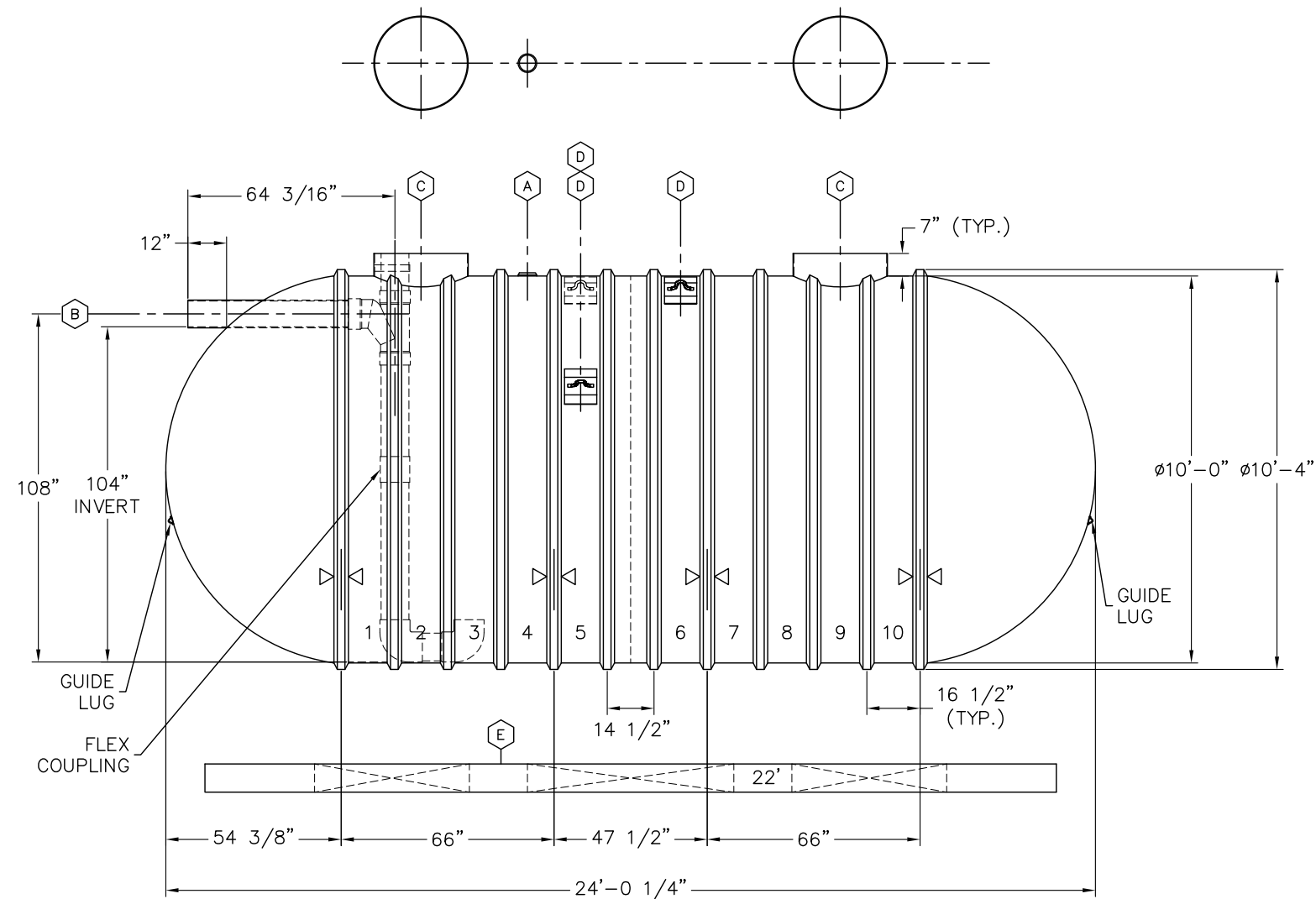

ITEM	QTY	DESCRIPTION
(A)	1	4"NPT SERVICE FITTING
(B)	1	8"DIA SCH 40 PVC INLET PIPE, INTERNAL SANITARY TEE & PIPES WITH SMOOTHING INLET & FLEXIBLE COUPLING
(C)	2	RISER PIPE, 29 3/8"O.D., FOR 30"(NOMINAL) ACCESS OPENING
(D)	3	LIFTING LUG (12" x 10") 22.5", 22.5", 45"
(E)	2	22' PREFABRICATED CONCRETE DEADMEN
▷◁	4	HOLD DOWN STRAP LOCATION

CUSTOMER  
 DESIGNATION:  
 RAINWATER CISTERN

00		REVISION DESCRIPTION			
DRN	DATE	CHK'D	DATE	APPR'D	DATE
<b>XERXES BY SHAWCOR</b>					
DRN	LJB	DATE	3-3-21	TITLE	10' DIA SW
CHK'D	PWM	DATE	3-3-21		CAP. 12,000 GALLONS
APPR'D	-	DATE	-		BIO SOLUTIONS
SALES MANAGER		DR. SIZE	DR. NUMBER	REV	
DAVID HOLMES		B	668-369	00	
		SCALE	N.T.S.	SHT	1 OF 1
INDUSTRY TYPE: M204 WATER COLLECTION AND CONSERVATION					



- NOTES:
1. INVERT DIMENSION FROM TANK I.D.
  2. ROTATE SHIPMENT ON TRAILER.
  3. ESTIMATED TANK WEIGHT: 4,200 lbs.

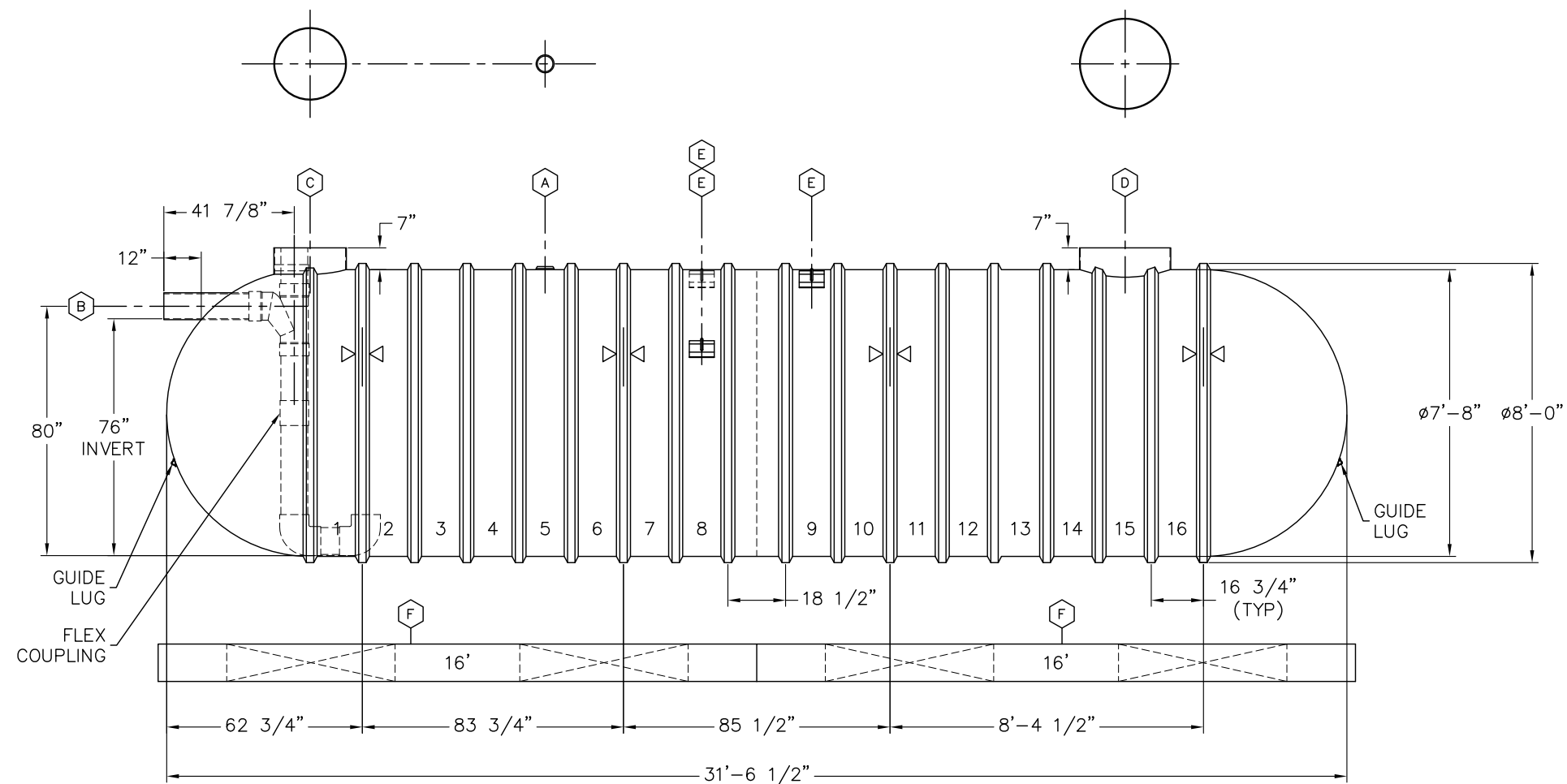

ITEM	QTY	DESCRIPTION
(A)	1	4"NPT SERVICE FITTING
(B)	1	8"DIA SCH 40 PVC INLET PIPE, INTERNAL SANITARY TEE & PIPES WITH SMOOTHING INLET & FLEXIBLE COUPLING
(C)	1	RISER PIPE, 23 3/8"O.D., FOR 24"(NOMINAL) ACCESS OPENING
(D)	1	RISER PIPE, 29 3/8"O.D., FOR 30"(NOMINAL) ACCESS OPENING
(E)	3	LIFTING LUG (10" x 8") 17", 17", 34"
(F)	4	16' PREFABRICATED CONCRETE DEADMEN
▷◁	4	HOLD DOWN STRAP LOCATION

CUSTOMER  
DESIGNATION:  
RAINWATER CISTERN

00		REVISION DESCRIPTION			
DRN	DATE	CHK'D	DATE	APPR'D	DATE
<b>XERXES BY SHAWCOR</b>					
DRN	DATE	TITLE			
LJB	3-3-21	8' DIA SW			
CHK'D	DATE	CAP. 10,000 GALLONS			
PWM	3-3-21	BIO SOLUTIONS			
APPR'D	DATE	DR. SIZE	DR. NUMBER	REV	
-	-	B	668-370	00	
SALES MANAGER		SCALE:	SHT		1 OF 1
DAVID HOLMES		N.T.S.			
INDUSTRY TYPE: M204 WATER COLLECTION AND CONSERVATION					

NOTES:

1. INVERT DIMENSION FROM TANK I.D.
2. ROTATE SHIPMENT ON TRAILER.
3. ESTIMATED TANK WEIGHT: 3,400 lbs.

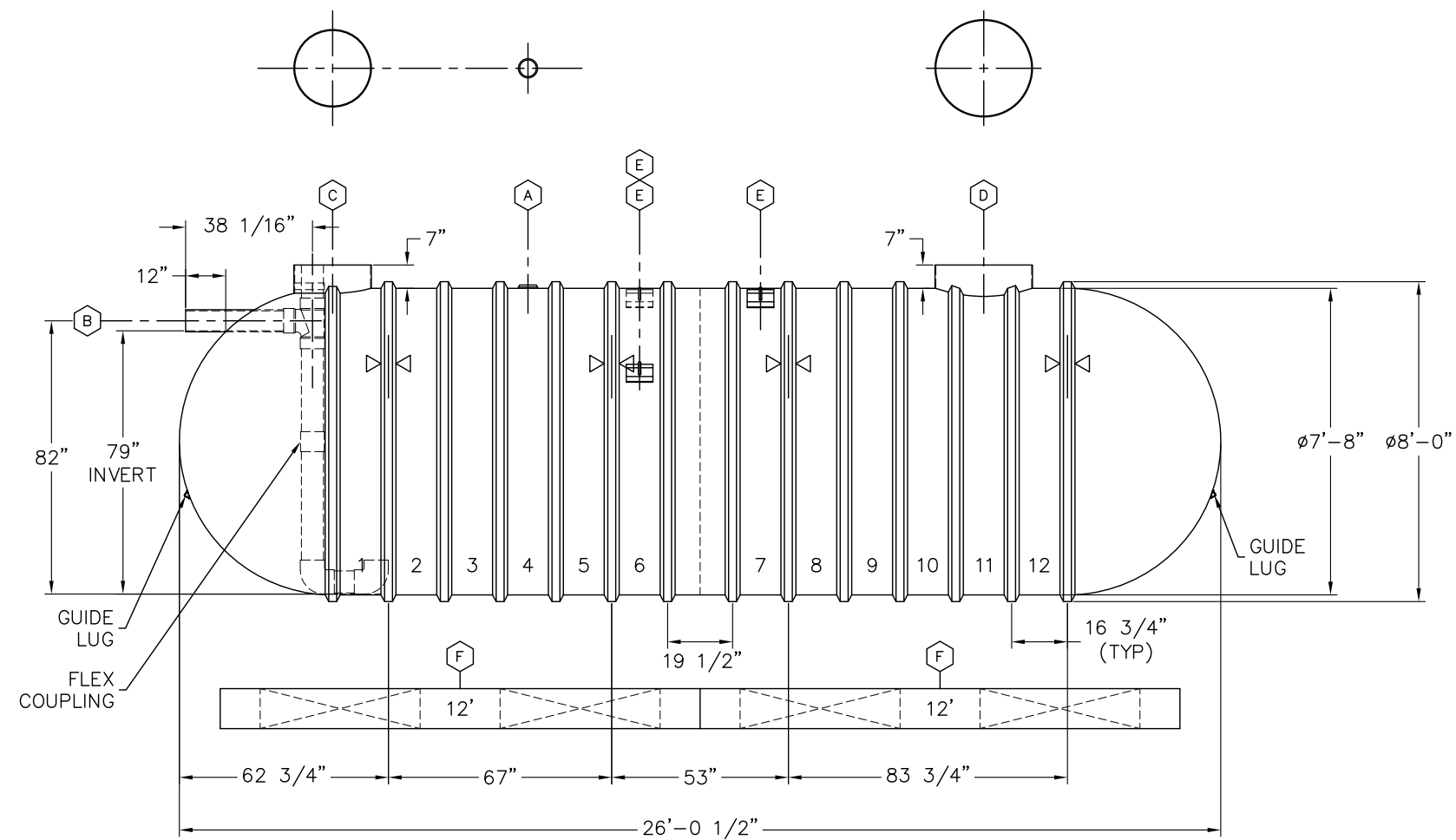

ITEM	QTY	DESCRIPTION
A	1	4"NPT SERVICE FITTING
B	1	6"DIA SCH 40 PVC INLET PIPE, INTERNAL SANITARY TEE & PIPES WITH SMOOTHING INLET & FLEXIBLE COUPLING
C	1	RISER PIPE, 23 3/8"O.D., FOR 24"(NOMINAL) ACCESS OPENING
D	1	RISER PIPE, 29 3/8"O.D., FOR 30"(NOMINAL) ACCESS OPENING
E	3	LIFTING LUG (10" x 8") 17", 17", 34"
F	4	12' PREFABRICATED CONCRETE DEADMEN
△	4	HOLD DOWN STRAP LOCATION

CUSTOMER  
DESIGNATION:  
RAINWATER CISTERN

00		REVISION DESCRIPTION			
DRN	DATE	CHK'D	DATE	APPR'D	DATE
<b>XERXES BY SHAWCOR</b>					
DRN	DATE	TITLE			
LJB	3-3-21	8' DIA SW			
CHK'D	DATE	CAP. 8,000 GALLONS			
PWM	3-4-21	BIO SOLUTIONS			
APPR'D	DATE				
SALES MANAGER		DR. SIZE	DR. NUMBER	REV	
DAVID HOLMES		B	668-371	00	
		SCALE:	N.T.S.	SHT 1 OF 1	
INDUSTRY TYPE: M204 WATER COLLECTION AND CONSERVATION					

NOTES:

1. INVERT DIMENSION FROM TANK I.D.
2. ROTATE SHIPMENT ON TRAILER.
3. ESTIMATED TANK WEIGHT: 2,200 lbs.

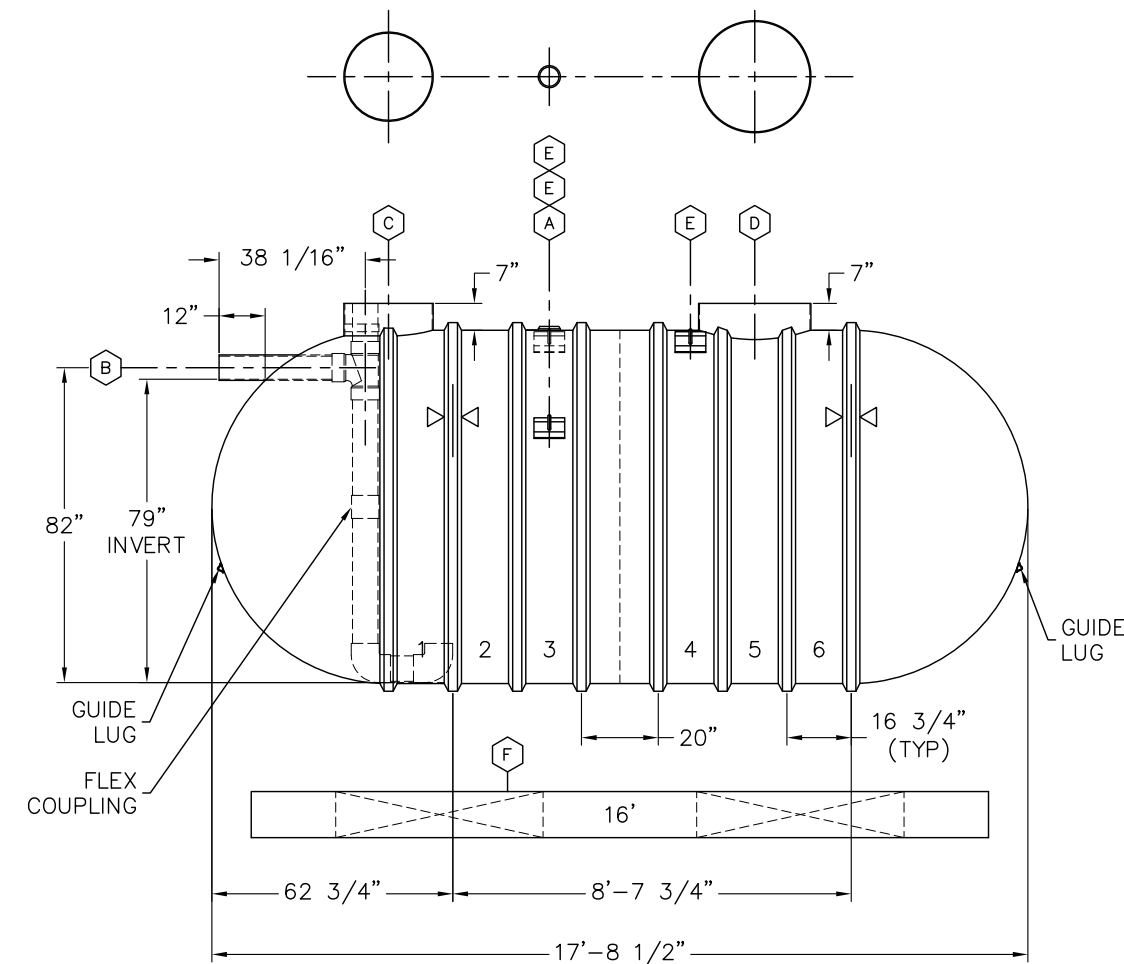

ITEM	QTY	DESCRIPTION
(A)	1	4"NPT SERVICE FITTING
(B)	1	6"DIA SCH 40 PVC INLET PIPE, INTERNAL SANITARY TEE & PIPES WITH SMOOTHING INLET & FLEXIBLE COUPLING
(C)	1	RISER PIPE, 23 3/8"O.D., FOR 24"(NOMINAL) ACCESS OPENING
(D)	1	RISER PIPE, 29 3/8"O.D., FOR 30"(NOMINAL) ACCESS OPENING
(E)	3	LIFTING LUG (10" x 8") 17", 17", 34"
(F)	2	16' PREFABRICATED CONCRETE DEADMEN
▷◁	2	HOLD DOWN STRAP LOCATION

CUSTOMER  
DESIGNATION:  
RAINWATER CISTERN

00		REVISION DESCRIPTION			
DRN	DATE	CHK'D	DATE	APPR'D	DATE
<b>XERXES BY SHAWCOR</b>					
DRN	DATE	TITLE			
LJB	3-4-21	8' DIA SW			
CHK'D	DATE	CAP. 5,000 GALLONS			
PJM	3-4-21	BIO SOLUTIONS			
APPR'D	DATE	DR. SIZE	DR. NUMBER	REV	
-	-	B	668-372	00	
SALES MANAGER		SCALE:	SHT 1 OF 1		
DAVID HOLMES		N.T.S.			
INDUSTRY TYPE: M204 WATER COLLECTION AND CONSERVATION					

- NOTES:
1. INVERT DIMENSION FROM TANK I.D.
  2. NOMINAL TANK WEIGHT : 1,600 lbs

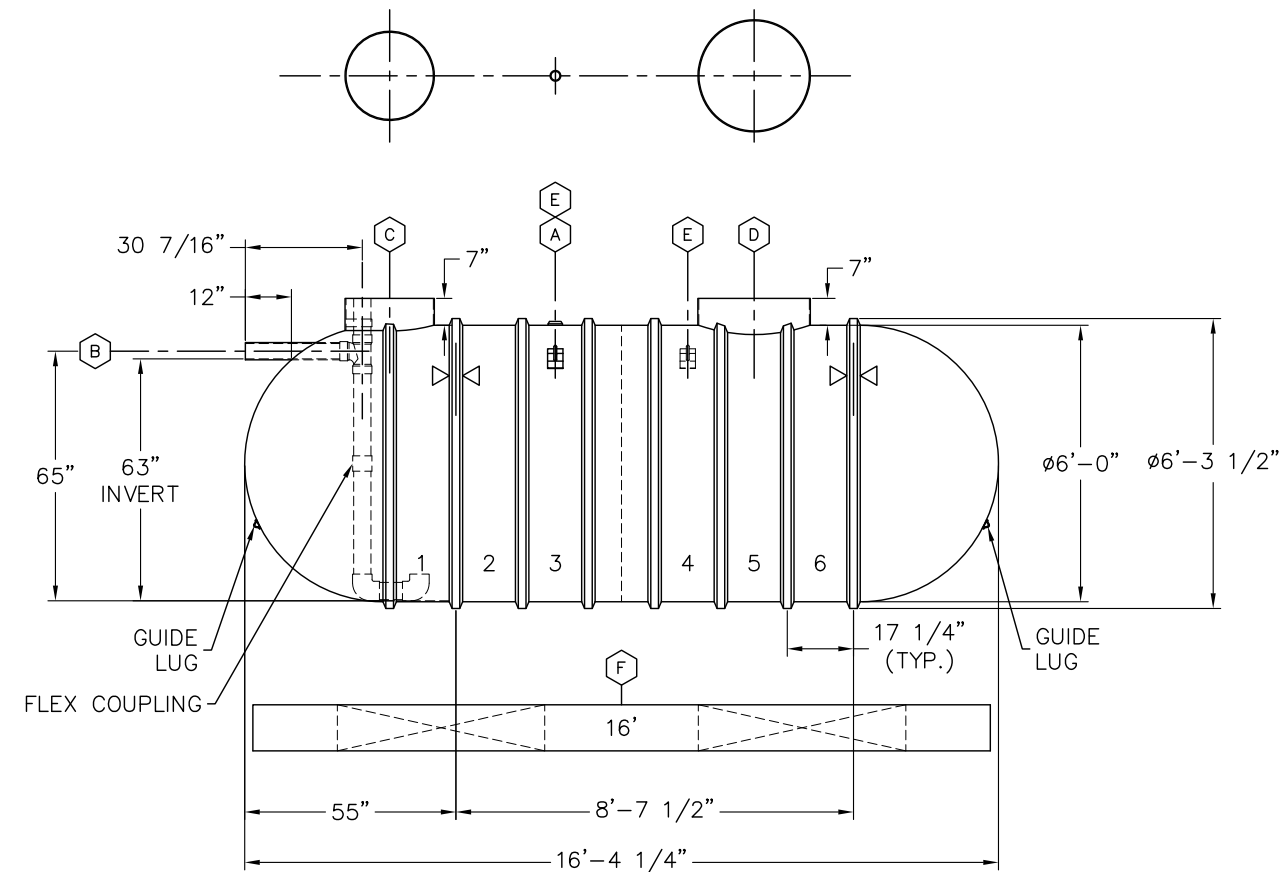

ITEM	QTY	DESCRIPTION
(A)	1	2"NPT SERVICE FITTING
(B)	1	4"DIA SCH 40 PVC INLET PIPE, INTERNAL SANITARY TEE & PIPES WITH SMOOTHING INLET & FLEXIBLE COUPLING
(C)	1	RISER PIPE, 23 3/8"O.D., FOR 24"(NOMINAL) ACCESS OPENING
(D)	1	RISER PIPE, 29 3/8"O.D., FOR 30"(NOMINAL) ACCESS OPENING
(E)	2	LIFTING LUG (10" x 4") 25", 25"
(F)	2	16' PREFABRICATED CONCRETE DEADMEN
▷◁	2	HOLD DOWN STRAP LOCATION

CUSTOMER  
DESIGNATION:  
RAINWATER CISTERN

00		REVISION DESCRIPTION			
DRN	DATE	CHK'D	DATE	APPR'D	DATE
<b>XERXES BY SHAWCOR</b>					
DRN	LJB	DATE	3-4-21	TITLE	6' DIA SW
CHK'D	PJM	DATE	3-4-21		CAP. 3,000 GALLONS
APPR'D	-	DATE	-		BIO SOLUTIONS
SALES MANAGER		DR. SIZE	DR. NUMBER	REV	
DAVID HOLMES		B	668-373	00	
		SCALE:	N.T.S.	SHT	1 OF 1
INDUSTRY TYPE: M204 WATER COLLECTION AND CONSERVATION					