

DuraFiber™ FLD and FLDR Access Lids

Applications

Orenco® DuraFiber™ Access Lids provide secure, damage-resistant coverings for ribbed PVC and HDPE risers, pump basins, and access ports. They are not recommended for vehicular traffic. 24-inch (600-mm) DuraFiber lids require an RLA24 adapter to mate to Perma-Loc™ pipe.

The FLDR30 series lids are required for use with RLA30 Riser-Lid-Adapters and for 30-inch (750-mm) Perma-Loc pipe applications. FLD30 series lids are not compatible with RLA30 Riser-Lid-Adapters or 30-inch Perma-Loc pipe.

General

DuraFiber Access Lids are designed for extreme durability and damage resistance, with breaking strengths in excess of 20,000 lbs (9,000 kg). Flat-style flanges provide easy access and clean, flush-to-grade installation. Centering rings align lids with risers; gaskets help provide watertight seals. DuraFiber Lids are available with optional insulation, installed at the factory or in kits that can be installed in the field. Optional stainless steel lid locks for FLD24 lids can be field-installed (FL-Lid Lock) or factory-installed (FL-Lid Lock-Adder).

DuraFiber Lids feature a non-skid surface, a molded-in caution statement, and room for a customer logo. They come with four 5/16-inch stainless steel flathead socket cap screws and a hex key wrench.

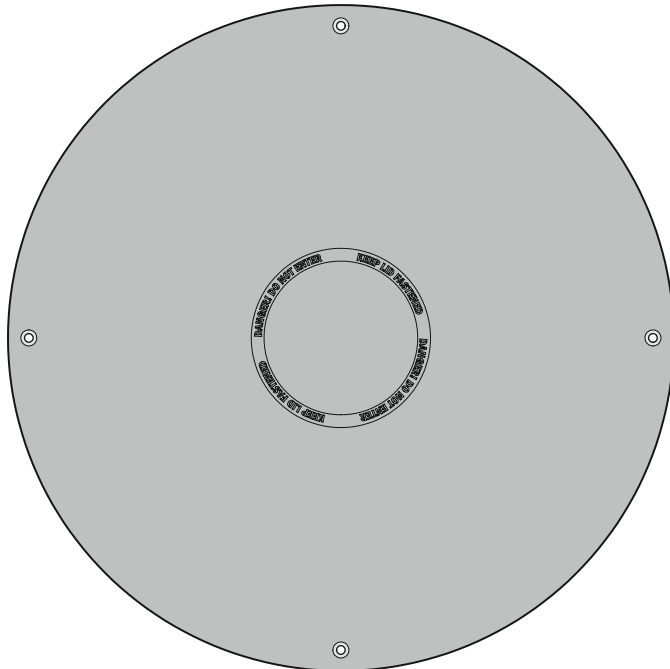

DuraFiber FLD lid, top view and side cutaway view

Standard Models

FLD18G, FLD24G, FLD24G-ATX, FLD24G-W, FLD30G, FLD30G-ATX, FLD30G-DELOS, FLD30G-W, FLDR30G

Product Code Diagram

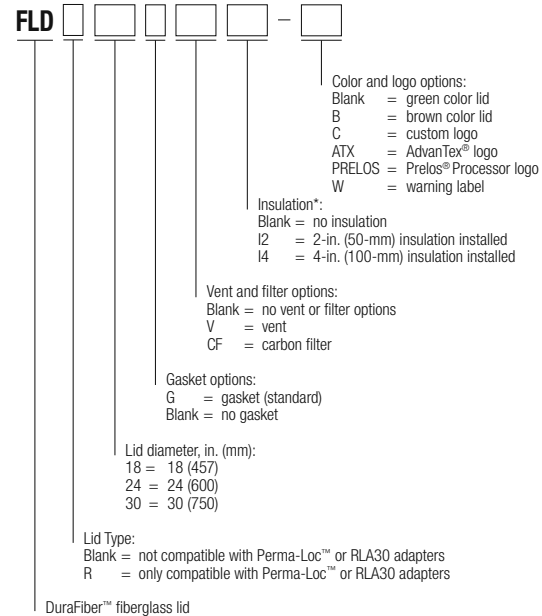

* Insulation has an R-value of 10 per 2-in. (25-mm) increment.

Materials of Construction

Lid	Fiberglass reinforced polyester (FRP)
Gasket	Urethane (FLD18)
Gasket	EPDM (FLD24, FLD30)
Centering ring core	Structural foam
Mounting hardware	Stainless steel
Insulation (optional)	Closed-cell foam
Insulation mounting hardware	Stainless steel

Specifications

Model	FLD18XX	FLD24XX	FLD30XX	FLDR30XX
A, in. (mm)	20.2 (514)	26 (660)	33 (838)	33 (838)
B, in. (mm)	1.5 (38)	1.5 (38)	1.5 (38)	1.5 (38)
C, in. (mm)	17.5 (445)	23.25 (590)	29.25 (743)	28.5 (724)
Gasket width, in. (mm)	0.75 (19)	0.75 (19)	0.75 (19)	1 (25)
Bolt hole diameter, in. (mm)	0.3125 (8)	0.3125 (8)	0.3125 (8)	0.3125 (8)
Weight, lbs (kg)	7 (3)	11 (5)	20 (9)	20 (9)
Bolt holes, per lid	4	4	4	4

