

CROSS-OVER & BAFFLE DETAIL

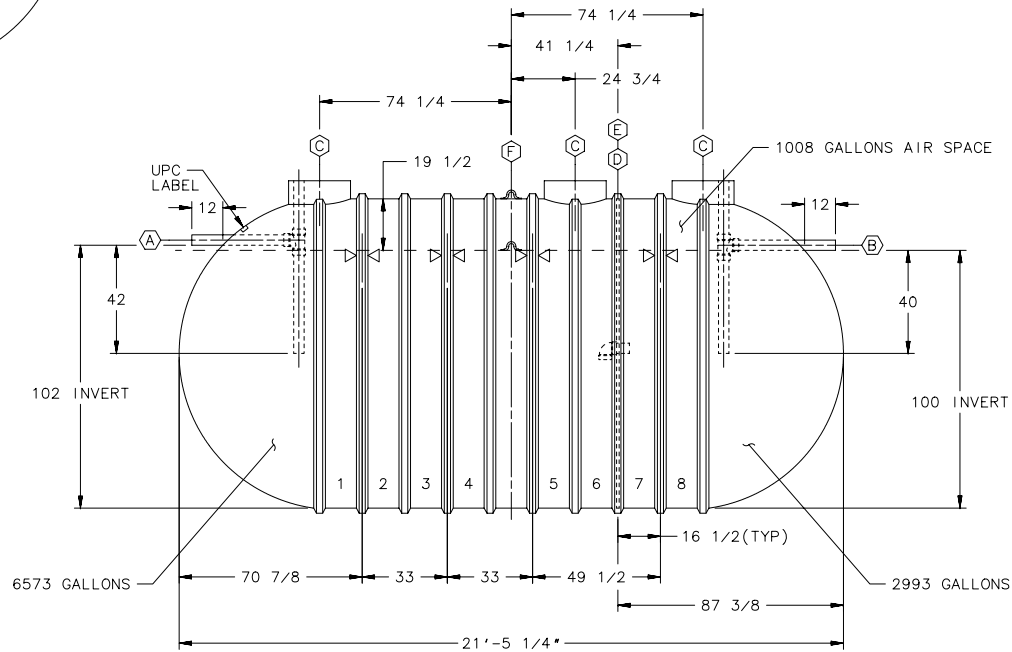

NOTE:

1 - UPC LABEL IS LAMINATED ONTO INLET SIDE OF TANK.

I hereby certify that this plan, specification or report was prepared by me or under my direct supervision and that I am a duly Registered Professional Engineer under the laws of the State of Minnesota

John R. Burwell

Date \_\_\_\_\_ Reg. No. 24679

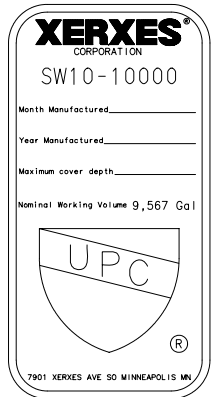

(A)	4"DIA, 6"DIA OR 8"DIA SCH 40 PVC INLET PIPE WITH INTERNAL SANITARY TEE & PIPES
(B)	4"DIA, 6"DIA OR 8"DIA SCH 40 PVC OUTLET PIPE WITH INTERNAL SANITARY TEE & PIPES
(C)	RISER PIPE, FOR 24*(NOMINAL) ACCESS OPENING
(D)	FULL PLATE BAFFLE WITH 1-4 5/8" DIA HOLE (59 3/4" INVERT) & 4" DIA VENT HOLE
(E)	4"DIA SCH 40 PVC CROSS-OVER ELBOW & PIPE
(F)	LIFTING LUG (2 LUGS TOTAL)
(X)	HOLD DOWN STRAP LOCATION

0		REVISION DESCRIPTION		BY DATE	
DRW'D	DATE	STP'S	DATE	APP'D	DATE
<b>XERXES CORPORATION</b> DR: DAG DATE: 7-19-06 TIT: 10" DIA SWT CAP: 10,000 GALLONS IAPMO		DR: JEB DATE: 7-25-06	DR: SIBZ DR: NAREBY	REV: D	REV: 628-348 00
		SCALE: 1/2"=1'-0"	NEXT ASS'Y:		SHT 1 OF 1